

The information contained in this drawing is the sole property of CWS Coil Winding Specialist. Any reproduction in part or whole without written permission of CWS Coil Winding Specialist is prohibited.

REVISION HISTORY

REV	ECN	DESCRIPTION	SIGN & DATE		
			BY	DATE	CHK
B		PRODUCTION RELEASE	TDK	5/08/06	JLJU
					5/08/06

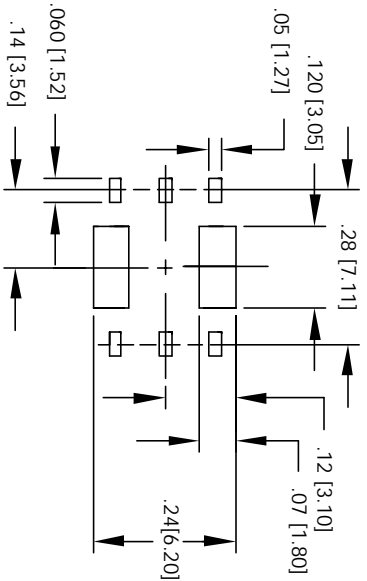
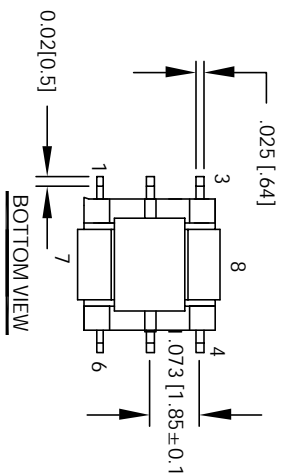
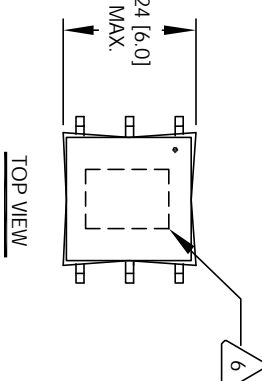
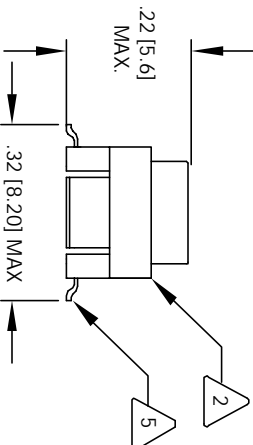
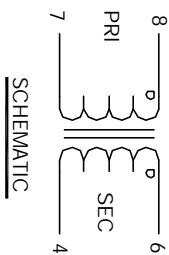

6 WHERE SHOWN
MARK PART NUMBER AND REVISION

5 REMOVE INSULATION, SOLDERED TO LEADS

4 CONSTRUCTION: ENCAPSULATED USING BOBBIN.
 FREQUENCY RANGE AT 100 KHZ AND ABOVE
 OPERATING TEMP. = - 25 °C TO 125 °C
 HI-POT PRIMARY TO SECONDARY = 500 Vrms
 PRIMARY CURRENT = 6 A MAX.
 SECONDARY DCR = 1.50 OHMS MAX
 SECONDARY INDUCTANCE@ 10 KHZ, 0.1 V = 500.0 uH MIN
 TURNS RATIO PRI:SEC = 1:50
 3 SPECIFICATIONS @ 25 °C :

2 WIRE: UL RECOGNIZED 130 °C RATED MAGNET WIRE
 CWS BYTE-MARK OR OTHER APPROVED PART
 CORE: FERRITE TOROID

1 BOBBIN RATING CLASS B (130 °C.) REQUIRED
 MATERIAL: UL RECOGNIZED 94V-0 FOR FLAMMABILITY
 NOTES: UNLESS OTHERWISE SPECIFIED, CURRENT SENSOR.
 UNIT: INCHES [MM]
 READ FROM BOTTOM UP

UNLESS OTHERWISE SPECIFIED
DIMENSIONING AND TOLERANCE PER ANSI Y14.5M
ALL DIMENSIONS ARE IN INCHES AND [DIMENSIONS]
TOLERANCE INCHES: .XXX ± .010 .XX ± .020 .X ± .030
TOLERANCE METRICES: .XXX ± .254 .XX ± .51 .X ± .030
ANGLE PROJECTION
DO NOT SCALE DRAWING

QTY	CODE	MFG. P/N	DESCRIPTION	ITEM NO.
	AUTOCAD			
	SOLIDWORKS			
	SIGN			
	DATE			
	DRAWN			
	PPR			
	DATE			
	DRWID			
	JLJU			
	DATE			
	ENGR			
	KSUM			
	DATE			
	APPR			
	JLJU			
	DATE			
	SCALE			
	B			
	SIZE			
	DMG. NO.			
	72-305			
	SCALE			
	4=1			
	SHEET			
	1			
	OF			
	1			