

The information contained in this drawing is the sole property of CWS Coil Winding Specialist. Any reproduction in part or whole without written permission of CWS Coil Winding Specialist is prohibited.

REVISION HISTORY

REV	ECN	DESCRIPTION	DATE	BY	CHK
A		PRODUCTION RELEASE	9/08/04	JLU	9/08/04



SCHEMATIC

6 WHERE SHOWN, USING A PERMANENT MARKING METHOD IF APPLICABLE, MARK PART NUMBER AND REVISION

5 FLUSH WITH THE COIL EDGE, AS SHOWN REMOVE INSULATION AND TIN LEADS APPROX. 0.25 INCH

4 WIND WIRE TO CORE EVENLY SPACED CONSTRUCTION:

3 HI-POT TEST FOR WIRE TO CORE = 500 VDC
 INDUCTANCE @ ± 20% RATED CURRENT = 3.0 uH
 DC CURRENT RATING = 10.5 AMPS MAX
 DCR = 5.9 MILLI-OHMS, MAX
 INDUCTANCE @ 0 AMPS = 3.9 uH, ± 20%, 1 KHZ, 0.25 Vrms
 SPECIFICATIONS @ 25 °C

2 WIRE: UL RECOGNIZED 130°C RATED MAGNET WIRE
 CORE: COATED MICROMETAL IRON POWDER
 CORE COATING RATING CLASS B (130°) REQUIRED
 MATERIAL: UL RECOGNIZED 94V-0 FOR FLAMMABILITY
 NOTES: UNLESS OTHERWISE SPECIFIED, TOROIDAL INDUCTOR

HORIZONTAL CONFIGURATION

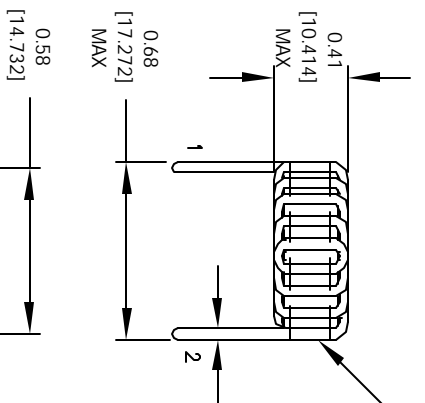

VERTICAL CONFIGURATION

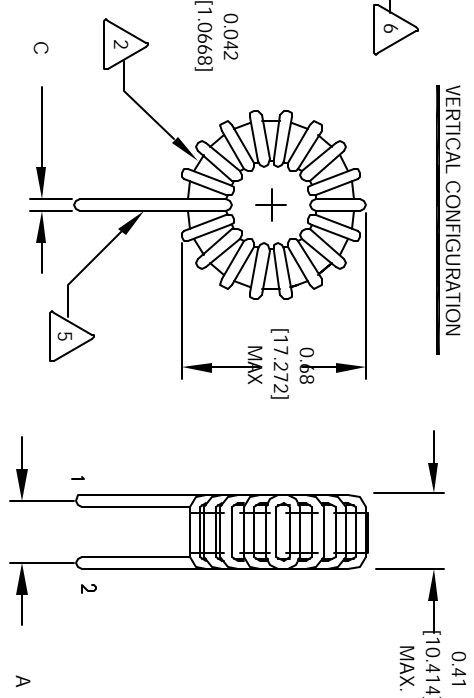

MOUNTING HOLES PATTERN

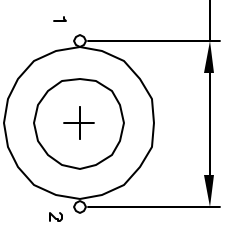

MOUNTING HOLES PATTERN

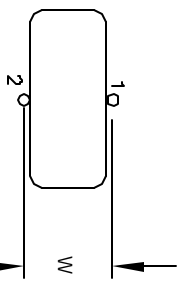

CODE IDENT	MFG. P/N	DESCRIPTION	ITEM NO.
AUTOCAD SIGN	X		
SOLIDWORKS SIGN			
DATE			
<p>PARTS LIST</p> <p>CWS Coil Winding Specialist 1510 E. Edinger Ave. Unit B, Santa Ana, CA 92705</p>			
<p>High Current Toroidal Inductors Vertical & Horizontal</p>			
SIZE	DRW. NO.		REV
B	J20-3R9H		A
SCALE	2=1	SHEET	1 OF 1