

The information contained in this drawing is the sole property of CWS Coil Winding Specialist. Any reproduction in part or whole without written permission of CWS Coil Winding Specialist is prohibited.

REVISION HISTORY

REV	ECN	DESCRIPTION	DATE	BY	DATE	CHK	DATE
B		PRODUCTION RELEASE	9/20/04	RRR	9/20/04	JLU	9/20/04

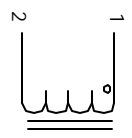

SCHEMATIC

- 6 ON TOP OF COVER
IF APPLICABLE, MARK PART NUMBER

- 5 TINNED TERMINALS

- 4 CONSTRUCTION:
MIN. Q = 80
MAX DC RESISTANCE = 5.5 OHMS
WINDING WIRE SIZE = 0.12 MM
L = 1.0 mH ± 10%, 25.2 KHZ
OPERATING TEMP = -20 °C TO +100 °C
MAX TEMP. RISE = 20 °C

- 3 SPECIFICATIONS:

- 2 EPOXY: 2 PART HIGH TEMP.
OUTER JACKET: 94V-0 INSULATOR
WIRE: UL RECOGNIZED 130 °C RATED MAGNET WIRE
CWS BYTE-MARK OR OTHER APPROVED PART
CORE: POWER FERRITE DRUM CORE

- 1 BOBBIN RATING CLASS B (130°C) REQUIRED
MATERIAL: UL RECOGNIZED 94V-0 FOR FLAMMABILITY

NOTES: UNLESS OTHERWISE SPECIFIED.

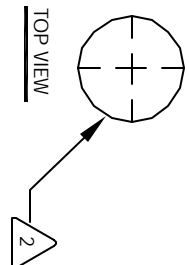

TOP VIEW

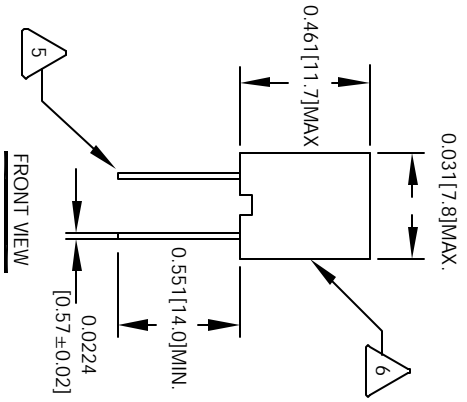

FRONT VIEW

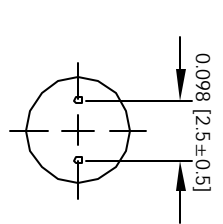

MOUNTING HOLES PATTERN

UNLESS OTHERWISE SPECIFIED
DRAWING AND TOLERANCE PER ANSI Y14.5M
ALL DIMENSIONS ARE IN INCHES AND [DIMENSIONS]
TOLERANCE ANGLES: ±0.30°
±0.010, ±0.020 TOLERANCE METRICS
±0.254, ±0.51
ANGLE PROJECTION
DO NOT SCALE DRAWING

QTY	CODE	MFG. P/N	DESCRIPTION	ITEM NO.
	IDENT			
	X			
AUTOCAD SOLIDWORKS SIGN		PARTS LIST		
DATE	DATE	CWS Coil Winding Specialist 1510 E. Edinger Ave. Unit B, Santa Ana, CA 92705		
9/20/04	9/20/04	Potted Radial Power Chokes		
9/20/04	9/20/04	SIZE	MFG. NO.	REV
9/20/04	9/20/04	B	M0711-102K	B
9/20/04	9/20/04	SCALE	2=1	SHEET 1 OF 1