

The information contained in this drawing is the sole property of CWS Coil Winding Specialist. Any reproduction in part or whole without written permission of CWS Coil Winding Specialist is prohibited.

REVISION HISTORY

REV	ECN	DESCRIPTION	DATE	BY	CHK	DATE
A		PRODUCTION RELEASE	9/08/04	JLU		9/08/04



SCHEMATIC

6 WHERE SHOWN, USING A PERMANENT MARKING METHOD IF APPLICABLE, MARK PART NUMBER AND REVISION

5 REMOVE INSULATION AND TIN LEADS APPROX. 0.5 INCH

4 WIND WIRE TO CORE EVENLY SPACED CONSTRUCTION:

WEIGHT = 29.6 GRAMS  
 HI-POT TEST FOR WIRE TO CORE = 500 VDC  
 INDUCTANCE @ RATED CURRENT = 120.00 uH  
 DC CURRENT RATING = 5.0 AMPS MAX  
 DCR = 52.5 MILLI-OHMS, MAX  
 INDUCTANCE @ 0 AMPS = 320.0 uH, ± 20%, 1 KHZ., 0.25 VRMS  
 SPECIFICATIONS @ 25 °C

2 WIRE: UL RECOGNIZED 130°C RATED MAGNET WIRE  
 CORE: COATED MICROMETAL IRON POWDER  
 CORE COATING RATING CLASS B (130°) REQUIRED  
 MATERIAL: UL RECOGNIZED 94V-0 FOR FLAMMABILITY  
 NOTES: UNLESS OTHERWISE SPECIFIED, TOROIDAL INDUCTOR

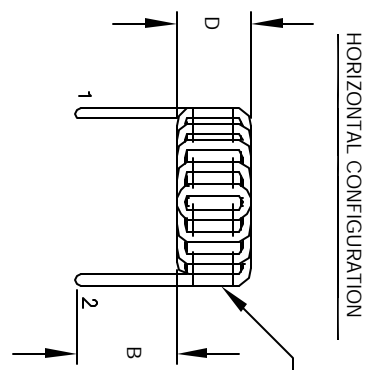

HORIZONTAL CONFIGURATION

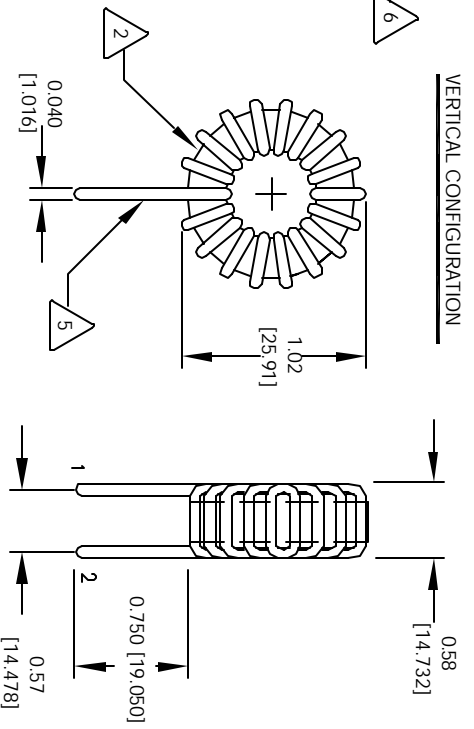

VERTICAL CONFIGURATION

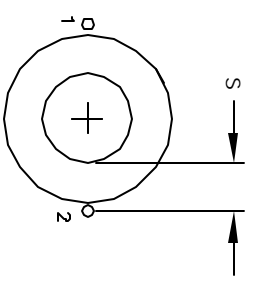

MOUNTING HOLES PATTERN

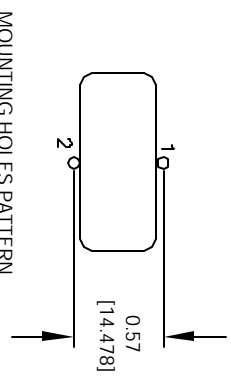

MOUNTING HOLES PATTERN

CODE IDENT	MFG. P/N	DESCRIPTION	ITEM NO.
		<b>PARTS LIST</b>	
AUTOCAD	X	CWS Coil Winding Specialist.	
SOLIDWORKS		www.cotlws.com	
SIGN	DATE	1510 E. Edinger Ave.	
		Unit B, Santa Ana, CA, 92705	
UNLESS OTHERWISE SPECIFIED		TITLE: Power Toroidal Inductors	
TOLERANCE PER ANSI Y14.5M	DATE	Vertical & Horizontal	
ALL DIMENSIONS ARE IN NOTES	DRAWN	DATE	SIZE
AND DIMENSIONS	RRR	9/08/04	DMR
	JLU	9/08/04	KSJM
	APPR.	9/08/04	JLU
	JLU	9/08/04	B
		SCALE	2=1
		SHEET	1 OF 1