

2

1

FOR REFERENCE ONLY

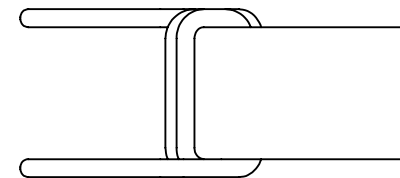
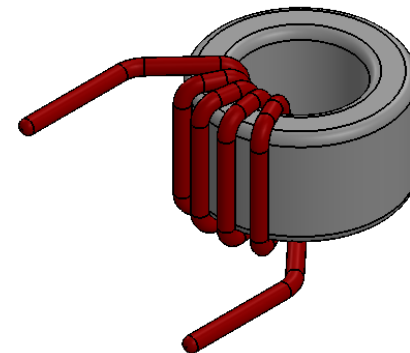
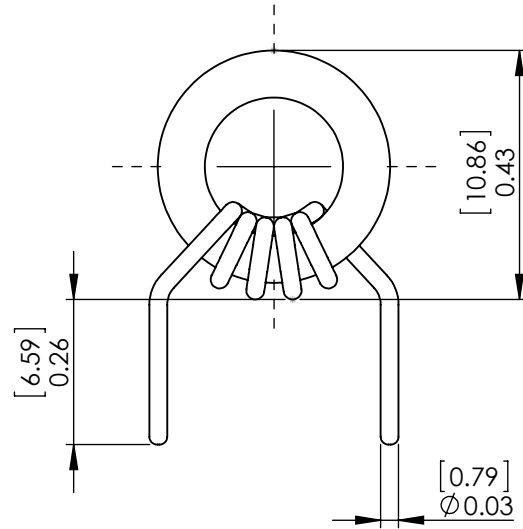

B

B

THE PART NUMBER ON THE WEBSITE.

4. PLEASE REFER TO OFFICIAL AUTOCAD PDF DRAWING BY CLICKING

3. DIMENSIONS ARE FOR REFERENCE ONLY WITH NO TOLERANCES.

THE SOLIDWORKS DRAWING.

2. DIMENSIONS SHOWN ARE FOR ONE TYPICAL UNIT USED IN

1. DRAWING DERIVED FROM SOLIDWORKS STEP FILE.

NOTES : UNLESS OTHERWISE SPECIFIED, READ FROM BOTTOM UP.

PROPRIETARY AND CONFIDENTIAL

THE INFORMATION CONTAINED IN THIS DRAWING IS THE SOLE PROPERTY OF COIL WINDING SPECIALIST, INC. ANY REPRODUCTION IN PART OR AS A WHOLE WITHOUT THE WRITTEN PERMISSION OF COIL WINDING SPECIALIST, INC. IS PROHIBITED.

UNLESS OTHERWISE SPECIFIED:

DIMENSIONS ARE IN INCHES
TOLERANCES:
FRACTIONAL \pm
ANGULAR: MACH \pm BEND \pm
TWO PLACE DECIMAL \pm
THREE PLACE DECIMAL \pm

INTERPRET GEOMETRIC
TOLERANCING PER:

MATERIAL

FINISH

DO NOT SCALE DRAWING

NAME DATE

DRAWN JJ 05/06/20

CHECKED TN 05/06/20

ENG APPR. JL 05/06/20

MFG APPR. JL 05/06/20

Q.A. JM 05/06/20

COMMENTS:

PDF DERIVED FROM
SOLIDWORKS

TITLE:

SolidWorks Version of
Differential Mode Choke
1.8 uH Min., 10Amps

SIZE

A

DWG. NO.

C-14123-00-SW

REV

A

SCALE: 3:1

WEIGHT:

SHEET 1 OF 1

2

1

A

A