

The information contained in this drawing is the sole property of CWS Coil Winding Specialist.
Any reproduction in part or whole without written permission of CWS Coil Winding Specialist is prohibited.

REVISION HISTORY						
REV	ECN	DESCRIPTION	SIGN & DATE			
			BY	DATE	CHK	DATE
B		PRODUCTION RELEASE	TDK	7/15/03	JLAU	7/15/03
C		CHANGE TO AWG#15 w/ 21 TURNS	TDK	1/05/04	JLAU	1/05/04
D		WIRE CLASS TO CL 155 OR HIGHER	TDK	1/05/05	JLAU	1/05/05
E		REVISED DIMENSION, ROHS COMPLIANCE	KLC	5/5/09	AM	5/5/09
F		UPDATED	RCL	7/6/11	JLAU	7/6/11

7 BUILD TO ROHS COMPLIANCE - LEAD FREE

WHERE SHOWN, USING A PERMANENT MARKING METHOD MARK PART NUMBER AND REVISION IN APPROX WRAP INDUCTOR WITH TAPE, (PER NOTE 2)

TO THE CORE MUST REST FLAT ON PCB). LEADS MUST BE TANGENT FLUSH WITH THE COIL EDGE, AS SHOWN (I.E. COIL REMOVE INSULATION AND TIN LEADS APPROX. 0.25 INCH

CORE AND EVENLY SPACED. LAST TURN OVERLAP A LITTLE WIND SINGLE LAYER ON CONSTRUCTION:

HI-POT TEST FOR CORE TO WINDING ISOLATION, 250VDC
RATED CURRENT= 12 AMPS
DCR= 8.16 mOHMS MAX./COIL.
L= 27uH MIN ,1KHZ,1Vrms.
SPECIFICATIONS @ 25 °C :

APPROVED PART
OUTER WRAP: MYLAR 3M#1350 OR EQUAL
WIRE: UL RECOGNIZED 155°C RATING MAGNET WIRE OR HIGHER
CWS BYTEMARK OR OTHER APPROVED PART
CORE: COATED POWDER CORE

CLASS B (130°C) REQUIRED
MATERIAL: UL RECOGNIZED 94V-0 FOR FLAMMABILITY

NOTES: UNLESS OTHERWISE SPECIFIED. READ FROM BOTTOM UP.

CAGE CODE = 5DME2

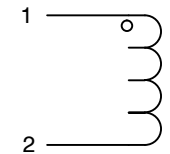
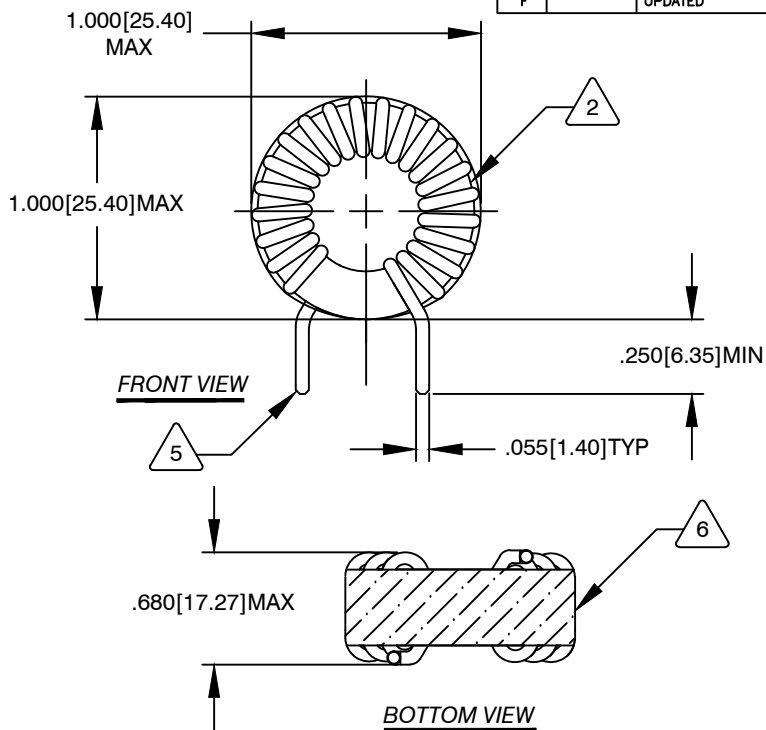

SCHEMATIC

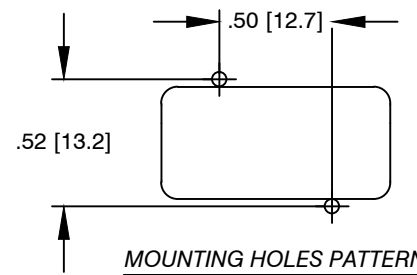

MOUNTING HOLES PATTERN

QTY	CODE IDENT	MFG. P/N	DESCRIPTION	ITEM NO.	
PARTS LIST					
AUTOCAD		X			
SOLIDWORKS					
SIGN		DATE	COILWS COM, INC www.coilws.com	CWS Coil Winding Specialist. 353 W Grove Ave Orange, CA 92865	
DRAWN	TDK	1/05/05	TITLE: Differential Mode Choke 27 uH, 12 Amp		
CHECKED	JLAU	1/05/05			
ENGR.	KSUM	1/05/05			
APPR.	JLAU	1/05/05	SIZE B	DWG. NO. C-14563-00	REV F
SCALE 1=2			SHEET 1 OF 1		

UNLESS OTHERWISE SPECIFIED	
DIMENSIONING AND TOLERANCE PER ANSI Y14.5M	
ALL DIMENSIONS ARE IN INCHES AND [MILLIMETERS].	
TOLERANCE INCHES: .XXX=±.010 .XX=±.020 ∠=±0°30'	
TOLERANCE METRICS: .XXX=±.254 .XX=±.51 ∠=±0°30'	
ANGLE PROJECTION	
DO NOT SCALE DRAWING	

CAD-FILE: