

The information contained in this drawing is the sole property of Coil Winding Specialist, Inc. Any reproduction in part or whole without written permission of Coil Winding Specialist, Inc. is prohibited.

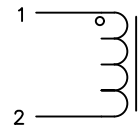

REVISION HISTORY						
REV	ECN	DESCRIPTION	SIGN & DATE			
			BY	DATE	CHK	DATE
A		PRODUCTION RELEASE	TN	08/31/2020	JL	08/31/2020



SCHEMATIC

DC BIAS TABLE

DC BIAS (AMP)	L@1KHz (REF)
0	2.23mH
2	2.23mH
4	2.15mH
6	2.06mH
8	1.92mH
10	1.75mH
12	1.60mH
14	1.45mH
16	1.30mH

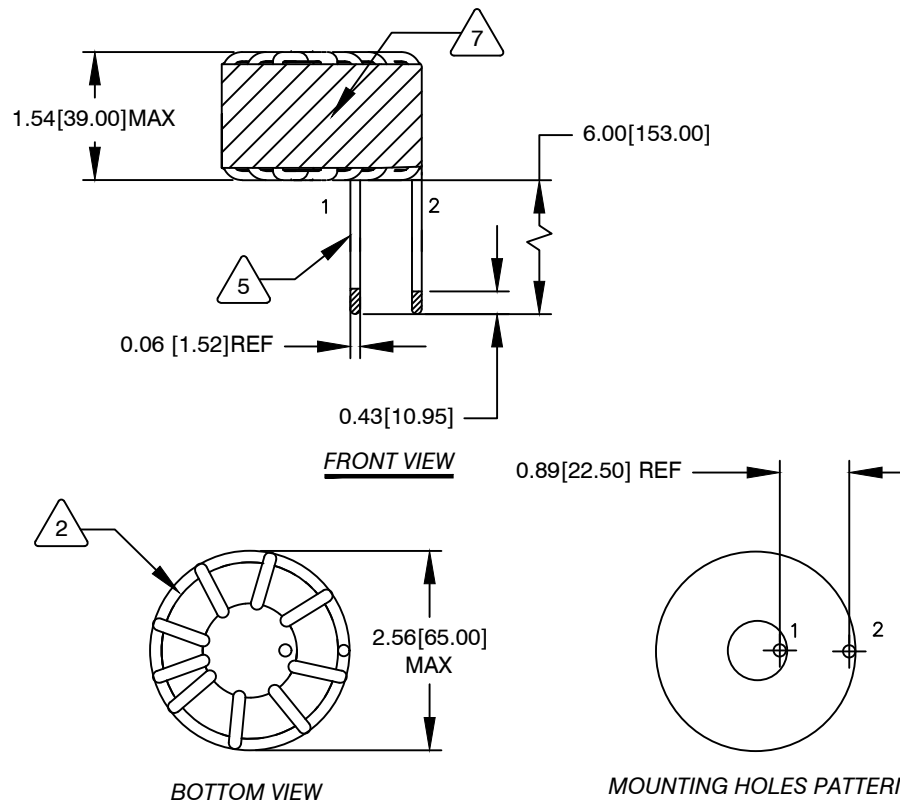

- 7 BUILD TO RoHS COMPLIANCE AND LEAD-FREE
- 6 LABEL PART NUMBER, REVISION AND DATE CODE
WRAP INDUCTOR WITH GLASS TAPE AND
- 5 REMOVE INSULATION AND TIN LEADS AS SPECIFIED LENGTH
WIND COILS EVENLY SPACED AROUND THE CORE
CONSTRUCTION:
- 4 WEIGHT: 567 GRAMS TYPICAL
HI-POT TEST FOR WINDING TO CORE ISOLATION = 500VDC MIN
OPERATING TEMP. RANGE = -40°C TO +125°C
INTERWINDING CAPACITANCE = 112pF TYP @ SRF
|Z| = 82 KILO-OHMS TYP @ SRF
SRF = 315 KHz TYPICAL
CURRENT RATING : 16 AMPS, 40°C TEMP. RISE WITH SOME AIRFLOW
DCR = 110.0 MILLI-OHMS MAX.
INDUCTANCE @ BIAS: SEE TABLE ON THE RIGHT.
INDUCTANCE = 2.20 mH ±10% @ LOW DC BIAS, 1 KHz, 250mV
SPECIFICATIONS @ 25°C:
- 3 WIRE: UL RECONIZED 200°C RATED MAGNET WIRE
CORE: TOROIDAL POWDERED CORE
- 2 RATING CLASS B (130°C MIN.) REQUIRED
MATERIAL: UL RECOGNIZED 94V-0 FOR FLAMMABILITY
- 1

WITHOUT ANY TOLERANCE. THIS DIM. CAN VARY A LITTLE FROM PART TO PART.
"TYP" IN DIM. TOL., IF APPLICABLE, REFERS TO A NON-CRITICAL TYPICAL (AVERAGE) DIM.

NOTES: UNLESS OTHERWISE SPECIFIED, READ NOTES FROM BOTTOM UP.

CAGE CODE: 5DME2

CODE IDENT	MFG. P/N	DESCRIPTION	ITEM NO.
PARTS LIST			
AUTOCAD	X	Coil Winding Specialist, Inc. 353 W Grove Ave Orange, CA 92865	
SOLIDWORKS			
DRAWN	TN 08/31/2020	TITLE: Toroidal Power Inductor 2.20mH, 16 Amps, Horizontal	
CHECKED	JM 08/31/2020		
ENGR.	JL 08/31/2020		
APPR.	JL 08/31/2020		
UNLESS OTHERWISE SPECIFIED		SIZE	REV
DIMENSIONING AND TOLERANCE PER ANSI Y14.5M ALL DIMENSIONS ARE IN INCHES AND [MILIMETERS]. TOLERANCE INCHES: .XXX=±.005 .XX=±.015 $\angle=±0°30'$ TOLERANCE METRICS: .XXX=±.127 .XX=±.38 $\angle=±0°30'$		DWG. NO.	A
ANGLE PROJECTION		CWS-1MF-11603	
DO NOT SCALE DRAWING		SCALE	SHEET 1 OF 1
		NOT_TO_SCALE	

CAD-FILE: