

The information contained in this drawing is the sole property of CWS Coil Winding Specialist.
Any reproduction in part or whole without written permission of CWS Coil Winding Specialist is prohibited.

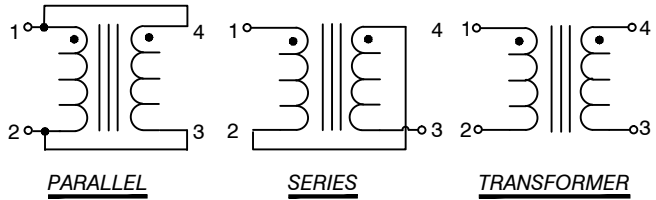

7 BUILD TO RoHS COMPLIANCE AND PB FREE
AND REVISION WHERE SHOWN
6 IF APPLICABLE MARK PART NUMBER

5 REMOVE INSULATION AND TIN LEADS

WIND ON TO CORE AND EVENLY SPACED
4 CONSTRUCTION:

TO INSURE INTEGRITY OF WINDING SEPARATION
HI-POT TEST FOR WINDING TO WINDING = 300 VDC MIN.
SERIES DCR= 0.236 OHMS MAX.
SERIES FULL LOAD CURRENT = 0.85 AMPS. DC.
SERIES FULL LOAD INDUCTANCE = 34.10 uH MIN.
SERIES OPEN CIRCUIT INDUCTANCE = 60.91 uH @ ± 20 %
PARALLEL DCR= 0.059 OHMS MAX.
PARALLEL FULL LOAD CURRENT = 1.70 AMPS. DC.
PARALLEL FULL LOAD INDUCTANCE = 8.53 uH MIN.
PARALLEL OPEN CIRCUIT INDUCTANCE = 15.23 uH @ ± 20 %

3 SPECIFICATIONS:

WIRE: UL RECOGNIZED 130°C RATING MAGNET WIRE
CWS BYTE MARK OR OTHER APPROVED PART
CORE: TOROID

BOBBIN RATING CLASS B (130°C) REQUIRED

1 MATERIAL: UL RECOGNIZED 94V-0 FOR FLAMMABILITY

NOTES: UNLESS OTHERWISE SPECIFIED. READ FROM BOTTOM UP.

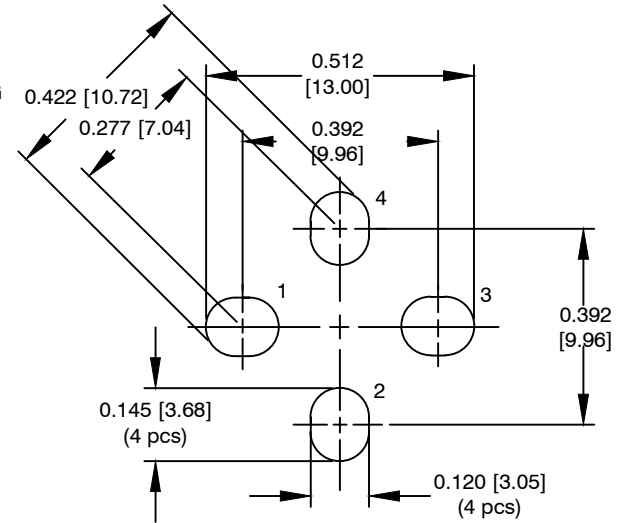
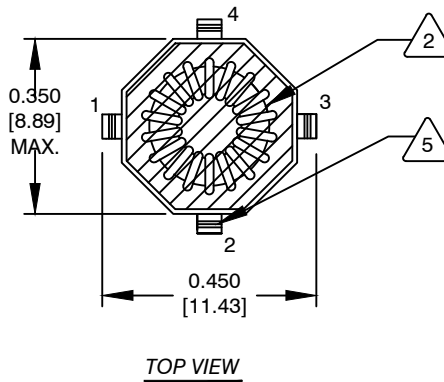
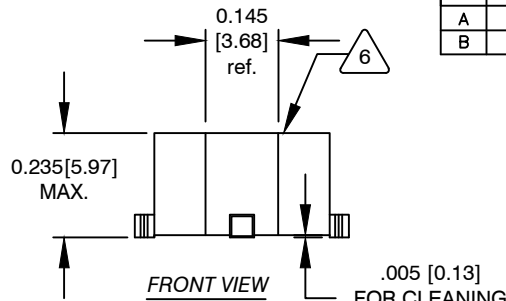

.005 [0.13]
FOR CLEANING
CLEARANCE

MOUNTING HOLES PATTERN

REVISION HISTORY						
REV	ECN	DESCRIPTION	SIGN & DATE			
			BY	DATE	CHK	DATE
A		PRODUCTION RELEASE	RPR	4/26/05	JLAU	4/26/05
B		FOOTPRINT AND NOTE UPDATE	RJL	4/30/11	JLAU	4/30/11

QTY	CODE IDENT	MFG. P/N	DESCRIPTION	ITEM NO.
PARTS LIST				
AUTOCAD		X		
SOLIDWORKS				
SIGN		DATE	sales@coilws.com www.coilws.com	Coil Winding Specialist, Inc. 353 W. Grove Avenue Orange, CA 92865
DRAWN	RPR	4/26/05	Parallel Series Inductor SIZE DWG. NO. CX15-2-SD SCALE NOT_TO_SCALE	
CHECKED	JLAU	4/26/05		
ENGR.	KSUM	4/26/05		
APPR.	JLAU	04/28/11		
			REV	B
			SHEET 1 OF 1	

UNLESS OTHERWISE SPECIFIED
DIMENSIONING AND TOLERANCE PER ANSI Y14.5M
ALL DIMENSIONS ARE IN INCHES AND [MILLIMETERS].
TOLERANCE INCHES:
.XXX=±.010 .XX=±.015 $\angle=±0°30'$
TOLERANCE METRICS:
.XXX=±.254 .XX=±.38 $\angle=±0°30'$
ANGLE PROJECTION

DO NOT SCALE DRAWING