

The information contained in this drawing is the sole property of CWS Coil Winding Specialist.  
Any reproduction in part or whole without written permission of CWS Coil Winding Specialist is prohibited.

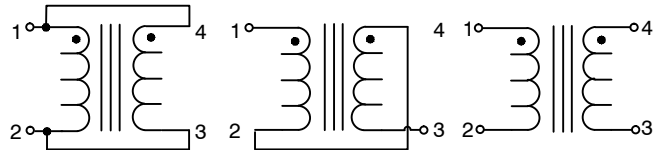

PARALLEL                      SERIES                      TRANSFORMER

7 BUILD TO RoHS COMPLIANCE AND PB FREE

AND REVISION WHERE SHOWN  
6 IF APPLICABLE MARK PART NUMBER

5 REMOVE INSULATION AND TIN LEADS

WIND ON TO CORE AND EVENLY SPACED

4 CONSTRUCTION:

TO INSURE INTERGRITY OF WINDING SEPARATION  
HI-POT TEST FOR WINDING TO WINDING = 300 VDC MIN.  
MAX DCR IS ± 15% OF TYPICAL VALUE.  
SERIES DCR= 0.961 OHMS TYP @ 20 °C  
SERIES RMS CURRENT = 0.64 AMPS.  
PARALLEL: (1,4 - 3,2 ), SERIES: (1 - 3) TIE (2 - 4).  
@ 100 KHZ, 0.250 VRMS, 0.0 ADC,  
SERIES OPEN CIRCUIT INDUCTANCE = 197.50 uH ± 25 %,

MAX DCR IS ± 15% OF TYPICAL VALUE  
PARALLEL DCR= 0.240 OHMS TYP @ 20 °C,  
DELTA TEMP 40 °C, AMBIENT TEMP 85 °C.  
PARALLEL RMS CURRENT = 1.28 AMPS @  
PARALLEL (1,4 - 3,2), SERIES (1 - 3) TIE (2 - 4).  
@ 100 KHZ, 0.250 VRMS, 0.0 ADC,  
PARALLEL OPEN CIRCUIT INDUCTANCE = 49.38 uH ± 25 %,  
PARALLEL RATED INDUCTANCE = 50.0 uH

3 SPECIFICATIONS:

WIRE: UL RECOGNIZED 130°C RATING MAGNET WIRE  
CWS BYTEMARK OR OTHER APPROVED PART  
CORE: TOROID

BOBBIN RATING CLASS B (130°C) REQUIRED

1 MATERIAL: UL RECOGNIZED 94V-0 FOR FLAMMABILITY

NOTES: UNLESS OTHERWISE SPECIFIED. READ FROM BOTTOM UP.

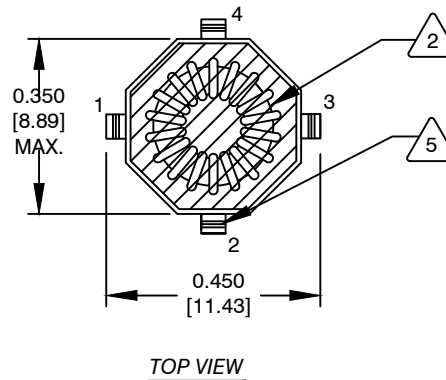
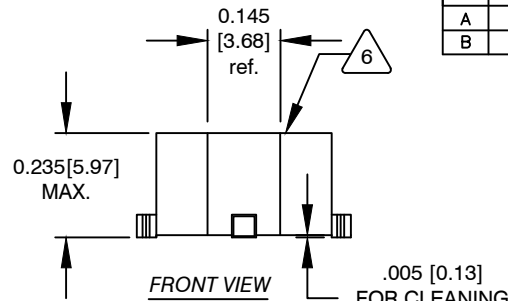

.005 [0.13]  
FOR CLEANING  
CLEARANCE

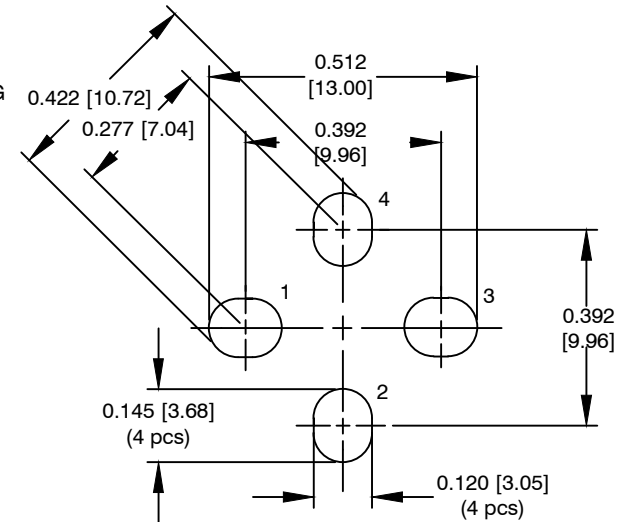

MOUNTING HOLES PATTERN

REVISION HISTORY						
REV	ECN	DESCRIPTION	SIGN & DATE			
			BY	DATE	CHK	DATE
A		PRODUCTION RELEASE	RPR	4/26/05	JLAU	4/26/05
B		FOOTPRINT AND NOTE UPDATE	RJL	4/30/11	JLAU	4/30/11

QTY	CODE IDENT	MFG. P/N	DESCRIPTION	ITEM NO.
<b>PARTS LIST</b>				
AUTOCAD		X		
SOLIDWORKS				
SIGN		DATE	<a href="mailto:sales@coilws.com">sales@coilws.com</a>	Coil Winding Specialist, Inc. 353 W. Grove Avenue Orange, CA 92865
DRAWN	RPR	4/26/05	<a href="http://www.coilws.com">www.coilws.com</a>	
CHECKED	JLAU	4/26/05	TITLE:	Parallel Series Inductor
ENGR.	KSUM	4/26/05	SIZE DWG. NO.	
APPR.	JLAU	04/28/11	SCALE	
			B	CX50-2-HF
			NOT_TO_SCALE	REV B
			SHEET 1 OF 1	

UNLESS OTHERWISE SPECIFIED  
DIMENSIONING AND TOLERANCE PER ANSI Y14.5M  
ALL DIMENSIONS ARE IN INCHES AND [MILLIMETERS].  
TOLERANCE INCHES:  
.XXX=±.010 .XX=±.015 <math>\angle=±0°30'</math>  
TOLERANCE METRICS:  
.XXX=±.254 .XX=±.38 <math>\angle=±0°30'</math>  
ANGLE PROJECTION   
DO NOT SCALE DRAWING