

The information contained in this drawing is the sole property of CWS Coil Winding Specialist.
Any reproduction in part or whole without written permission of CWS Coil Winding Specialist is prohibited.

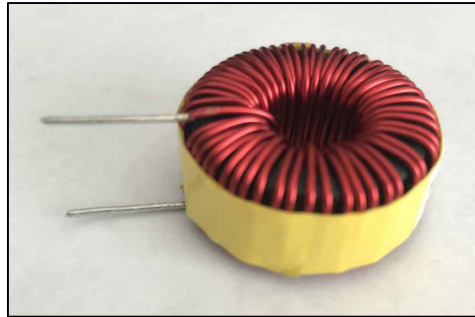

DIMENSIONAL TOLERANCES INCHES [MM]				
A	B	C	D	Y
MAX	MAX	MIN	REF	REF
1.22 [30.95]	.62 [15.80]	.50 [12.70]	.045 [1.15]	0.56 [14.34]

REVISION HISTORY						
REV	ECN	DESCRIPTION	SIGN & DATE			
			BY	DATE	CHK	DATE
A	-	INITIAL RELEASE	JLL	03/24/2011		
B	-	ELECT. AND MECHAN. SPEC. CHANGE	GN	08/31/2012	JL	08/31/2012
B1	-	UPDATED SPECS.	JZ	08/05/2020	JL	08/05/2020

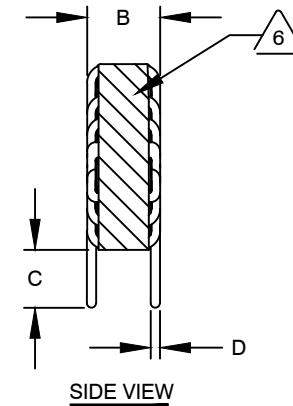
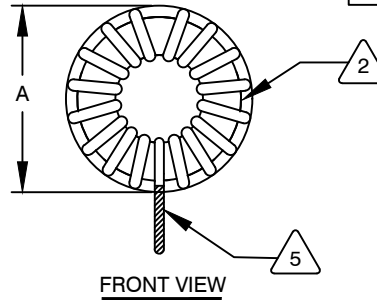
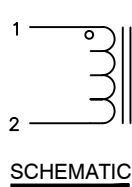

DC BIAS TABLE

DC BIAS (AMP)	L @ 1.0 KHz
0	504uH
1	434uH
2	361uH
3	288uH
4	229uH
4.5	204uH

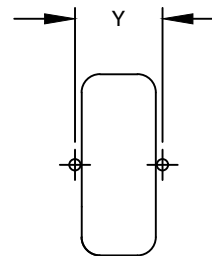

7 BUILD TO RoHS COMPLIANCE AND LEAD FREE.

USING A PERMANENT MARKING METHOD
MARK PART NUMBER AND REVISION, IF APPLICABLE,
WRAP INDUCTOR WITH 3M # 79 OR EQUAL



(I.E. COIL MUST REST FLAT ON PCB). LEADS MUST BE TANGENT TO THE CORE
REMOVE INSULATION AND TIN LEADS 0.50 INCH, FLUSH WITH THE COIL EDGE, AS SHOWN

4 CONSTRUCTION: WIND COILS EVENLY SPACED AROUND THE CORE

WEIGHT: 36 GRAMS TYPICAL
INTERWINDING CAPACITANCE = 26.15 pF TYP @ SRF
SRF = 1.7 MHz TYPICAL
|Z| = 29.7 KILO-OHMS TYP @ SRF
RECOMMENDED AMBIENT OPERATING TEMP: -40°C TO 200°C
HI-POT TEST FOR WINDING TO CORE ISOLATION = 500 VDC 10 SEC
CURRENT RATING : 4.5 AMPS, 40°C TEMP. RISE WITH SOME AIR FLOW
DCR = 63.0 MILLI-OHMS MAX.

INDUCTOR DC BIAS: SEE TABLE ON THE RIGHT

INDUCTANCE = 470 uH ± 15% @ 0 AMP DC BIAS, 1.0 KHz, 300mV

3 SPECIFICATIONS: @ 25° C



WIRE: UL RECOGNIZED 155°C RATED MAGNET WIRE
CORE: HIGH POWDERED TOROIDAL CORE, CWS BYTEMARK OR OTHER APPROVED PART

1 MATERIAL: UL RECOGNIZED 94V-0 FOR FLAMMABILITY, RATING CLASS B (130°C MIN.) REQUIRED

ANY TOLERANCE. THIS DIM. CAN VARY A LITTLE FROM PART TO PART.

"TYP" IN DIM. TOL. REFERS TO A NON-CRITICAL TYPICAL (AVERAGE) DIM. WITHOUT

NOTES: UNLESS OTHERWISE STATED, READ NOTES FROM BOTTOM UP.

CAGE CODE: 5DME2

UNLESS OTHERWISE SPECIFIED	
DIMENSIONING AND TOLERANCE PER ANSI Y14.5M	
ALL DIMENSIONS ARE IN INCHES AND [MILLIMETERS].	
TOLERANCE INCHES: .XXX = ±.005 .XX = ±.015 $\angle = \pm 0^{\circ}30'$	
TOLERANCE METRICS: .XXX = ±.127 .XX = ±.38 $\angle = \pm 0^{\circ}30'$	
ANGLE PROJECTION	
DO NOT SCALE DRAWING	

CODE IDENT	MFG. P/N	DESCRIPTION	ITEM NO.	
PARTS LIST				
AUTOCAD	X	COILWS COM, INC www.coilws.com	CWS Coil Winding Specialist. 353 WEST GROVE ORANGE, CA 92865	
SOLIDWORKS				
SIGN	DATE	TITLE: TOROIDAL POWER INDUCTOR 470 uH, 4.5 Amps, Vertical		
DRAWN	KLC 10/06/2008			
CHECKED	CT 10/06/2008			
ENGR.	KLC 10/06/2008			
APPR.	KLC 10/06/2008	SIZE	DWG. NO.	REV
		B	SN270-471M-4.5AV	B1
		SCALE	SHEET 1 OF 1	
		2=1		