

The information contained in this drawing is the sole property of CWS Coil Winding Specialist. Any reproduction in part or whole without written permission of CWS Coil Winding Specialist is prohibited.

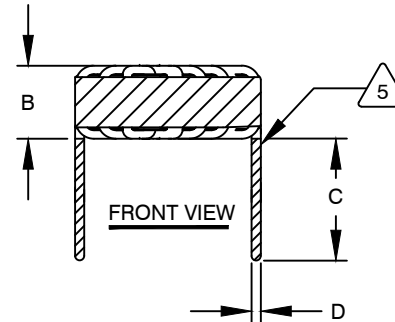

DIMENSIONAL TOLERANCES INCHES [MM]				
A	B	C	D	X
MAX	MAX	MIN	REF	REF
1.25 [31.75]	0.60 [15.36]	0.50 [12.70]	0.056 [1.43]	1.22 [31.08]

REVISION HISTORY						
REV	ECN	DESCRIPTION	SIGN & DATE			
			BY	DATE	CHK	DATE
A	-	INITIAL RELEASE	JLL	05/03/2011		
A1	-	UPDATED SPECS.	JZ	06/06/2021	JL	06/06/2021



**DC BIAS TABLE**

DC BIAS (AMP)	L @ 1.0 KHz
0	56.0uH
2	54.3uH
4	48.3uH
6	42.1uH
8	36.9uH
10	31.4uH

7 BUILD TO RoHS COMPLIANCE AND LEAD FREE.

USING A PERMANENT MARKING METHOD  
 MARK PART NUMBER AND REVISION, IF APPLICABLE  
 WRAP INDUCTOR WITH 3M # 79 OR EQUAL



(I.E. COIL MUST REST FLAT ON PCB). LEADS MUST BE TANGENT TO THE CORE  
 REMOVE INSULATION AND TIN LEADS 0.50 INCH, FLUSH WITH THE COIL EDGE, AS SHOWN



WIND COILS EVENLY SPACED AROUND THE CORE  
 CONSTRUCTION:

THESE SPECIFICATIONS ARE BASED ON LOW RIPPLE CURRENT  
 WEIGHT: 39 GRAMS TYPICAL  
 INTERWINDING CAPACITANCE = 15.3 pF TYP @ SRF  
 SRF = 5.6 MHz TYPICAL  
 |Z| = 5.6 KILO-OHMS TYP @ SRF  
 RECOMMENDED AMBIENT OPERATING TEMP: -40 °C TO 200°C  
 HI-POT TEST FOR WINDING TO CORE ISOLATION = 500 VDC 10 SEC  
 CURRENT RATING : 10 AMPS, 40 °C TEMP. RISE WITH SOME AIR FLOW  
 DCR = 8.77 MILLI-OHMS MAX.  
 INDUCTOR DC BIAS: SEE TABLE ON THE RIGHT  
 INDUCTANCE = 56 uH ± 15% @ 0 AMP DC BIAS, 1.0 KHz, 300mV

3 SPECIFICATIONS @ 25°C :



WIRE: UL RECOGNIZED 200°C RATED MAGNET WIRE  
 CORE: POWDERED TOROIDAL CORE, CWS BYTEMARK OR OTHER APPROVED PART

1 MATERIAL: UL RECOGNIZED 94V-0 FOR FLAMMABILITY, RATING CLASS H (180°C MIN.) REQUIRED

ANY TOLERANCE. THIS DIM. CAN VARY A LITTLE FROM PART TO PART.

"TYP" IN DIM. TOL. TABLE REFERS TO A NON-CRITICAL TYPICAL (AVERAGE) DIM. WITHOUT

NOTES: UNLESS OTHERWISE STATED, READ NOTES FROM BOTTOM UP.

CAGE CODE: 5DME2

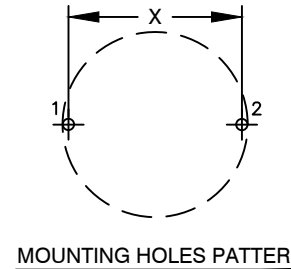
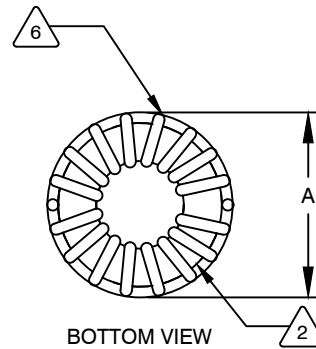

UNLESS OTHERWISE SPECIFIED  
 DIMENSIONING AND TOLERANCE PER ANSI Y14.5M  
 ALL DIMENSIONS ARE IN INCHES AND [MILLIMETERS].  
 TOLERANCE INCHES:  
 .XXX±.005 .XX±.015 <math>\angle = \pm 0'30''</math>  
 TOLERANCE METRICS:  
 .XXX±.127 .XX±.38 <math>\angle = \pm 0'30''</math>  
 ANGLE PROJECTION  
 DO NOT SCALE DRAWING

CODE IDENT	MFG. P/N	DESCRIPTION	ITEM NO.	
<b>PARTS LIST</b>				
AUTOCAD	X	<b>COILWS COM, INC</b> www.coilws.com	CWS Coil Winding Specialist. 353 W Grove Ave Orange, CA. 92865	
SOLIDWORKS				
SIGN	DATE	<b>TITLE:</b> <b>TOROIDAL POWER INDUCTOR</b> <b>56 uH, 10 Amps, Horizontal</b>		
DRAWN	KLC 10/06/2008			
CHECKED	CT 10/06/2008			
ENGR.	KLC 10/06/2008			
APPR.	JLAU 05/03/2011	SIZE	DWG. NO.	REV
		B	SN270-560M-10AH	A1
		SCALE	2=1	SHEET 1 OF 1