

# Thermal and Electromagnetics simulation – Part # HF400-651M-8.0A – Current rated 8A @ 1kHz

Current 30%  
(2.4A)  
No Airflow  
Natural  
convection

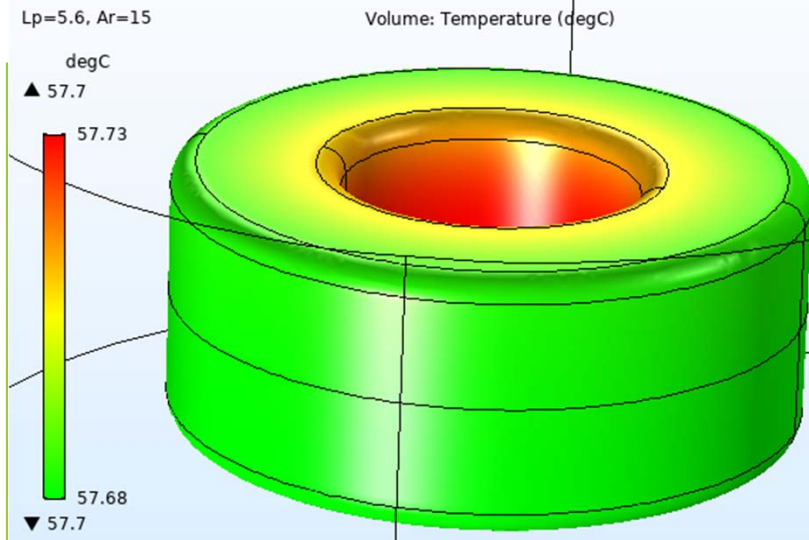

Current 70%  
(5.6A)  
15 W/(m<sup>2</sup>K) or  
3 m/s air flow.

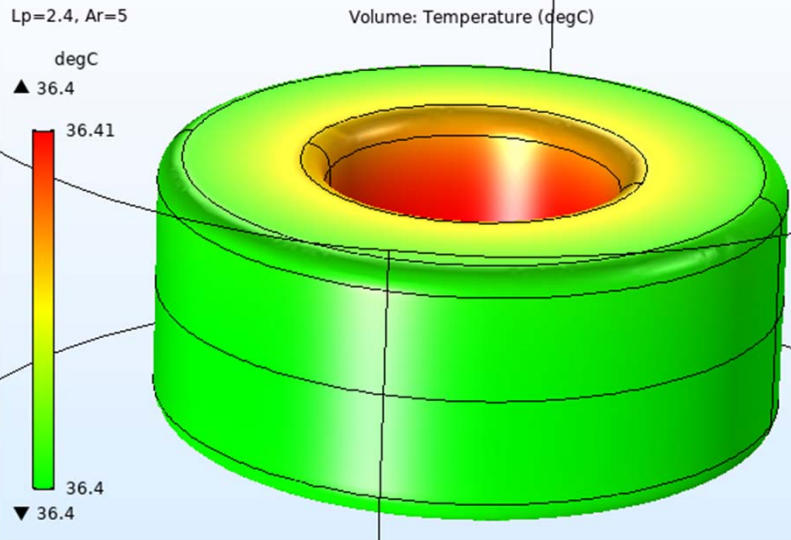
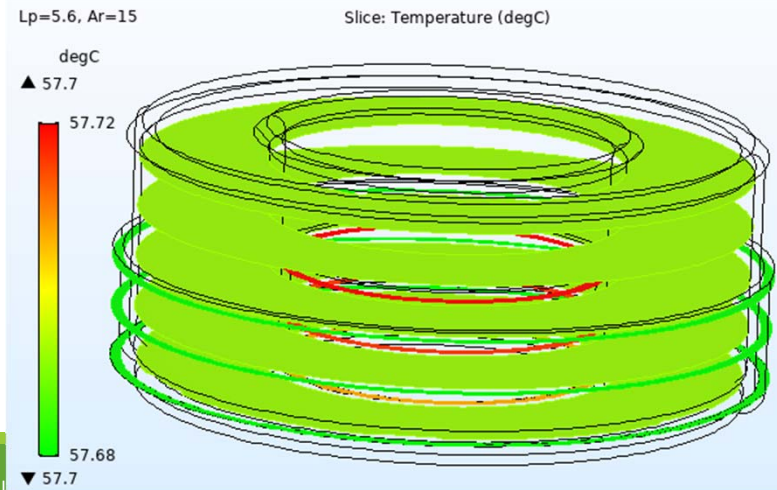
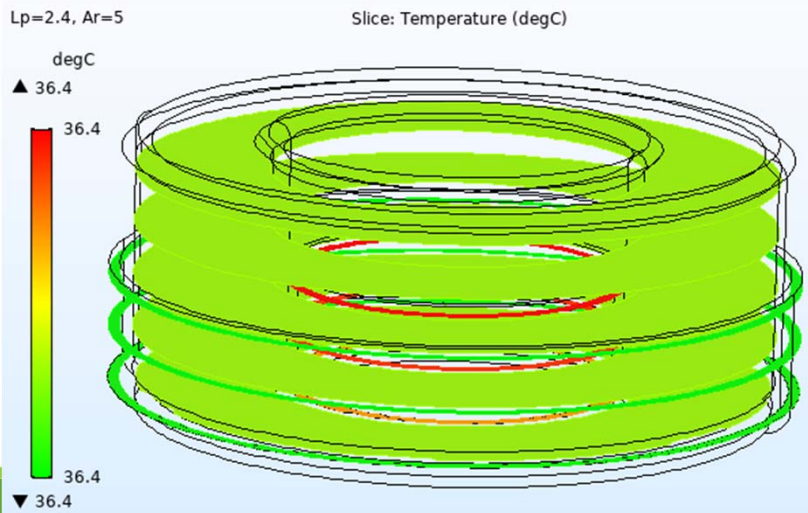

Thermal and Electromagnetics simulation – Part # HF400-651M-8.0A – Current rated 8A @ 1kHz

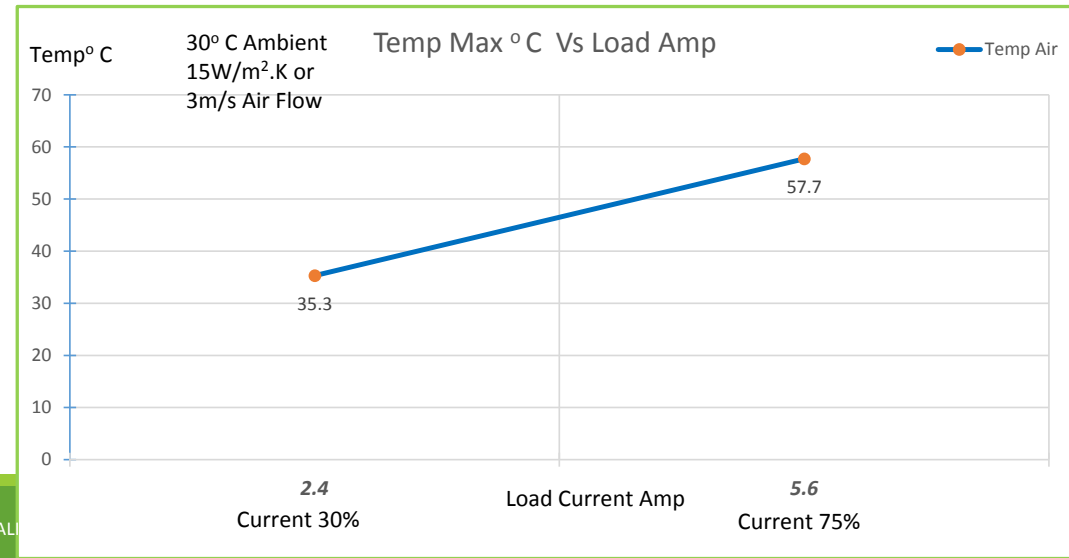
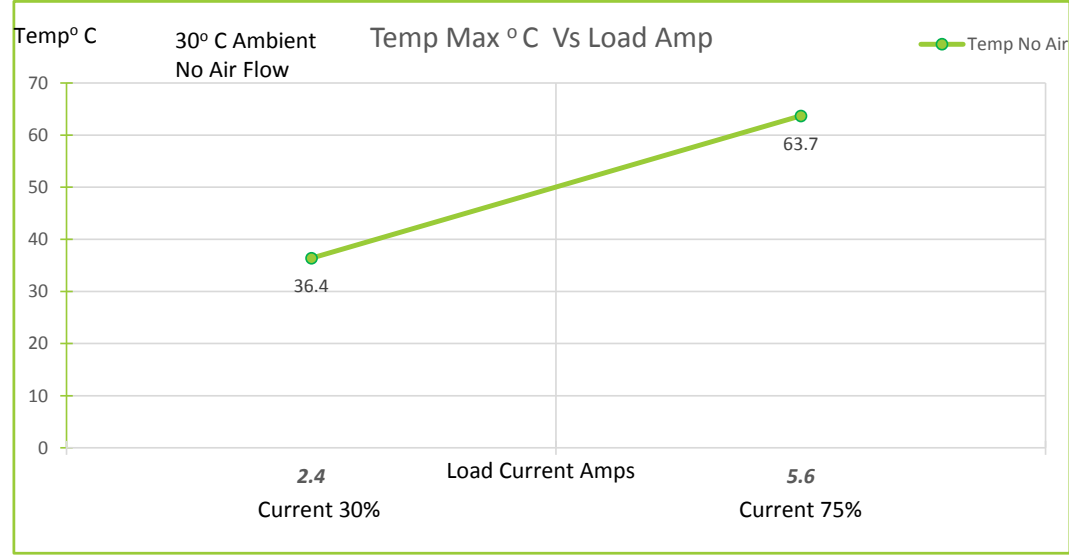
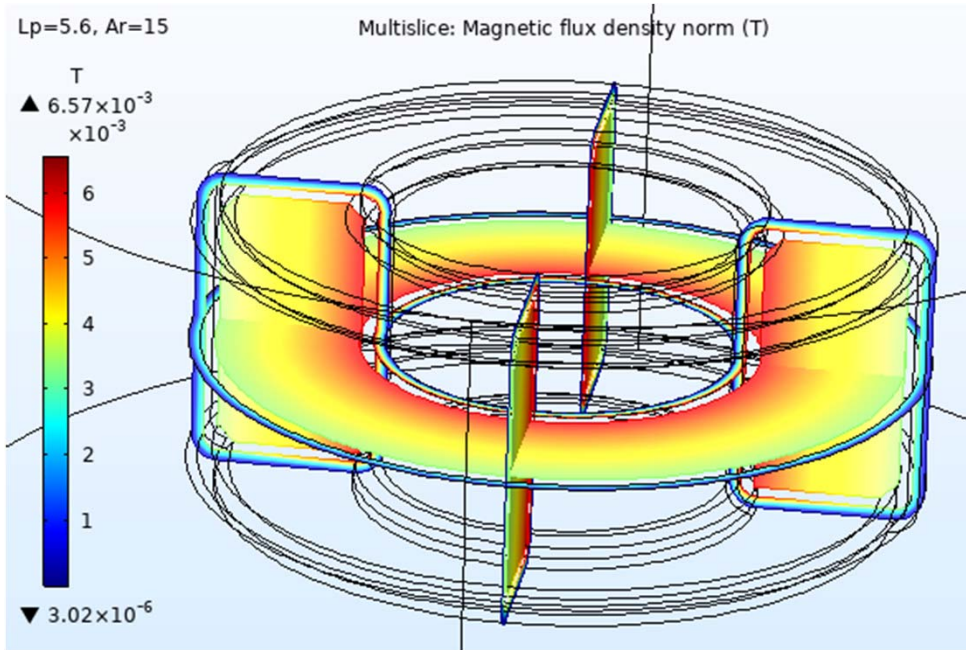

Thermal and Electromagnetics simulation -- Part # HF400-651M-8.0A -- Current rated 8A @ 1kHz

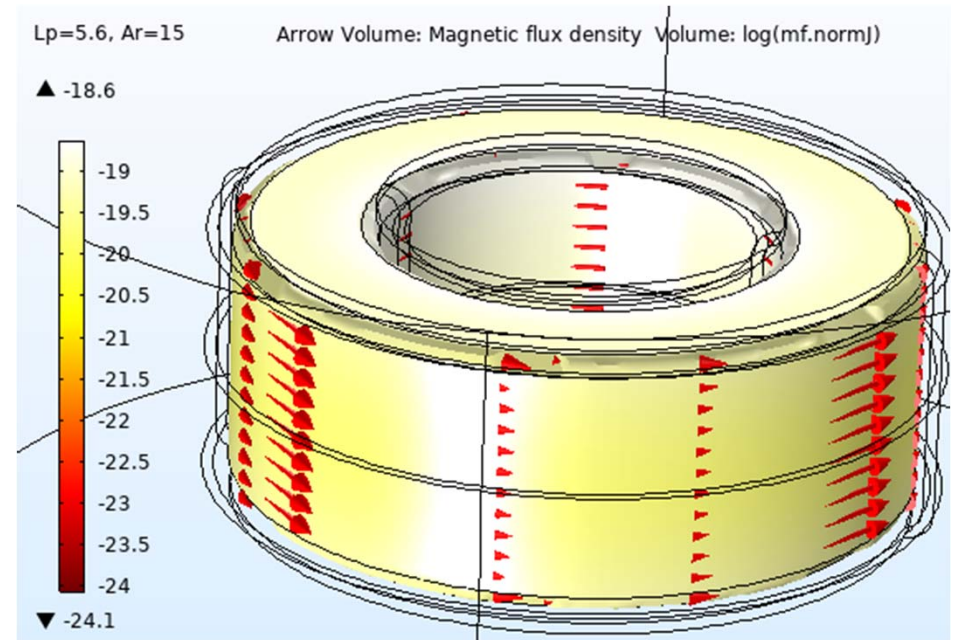
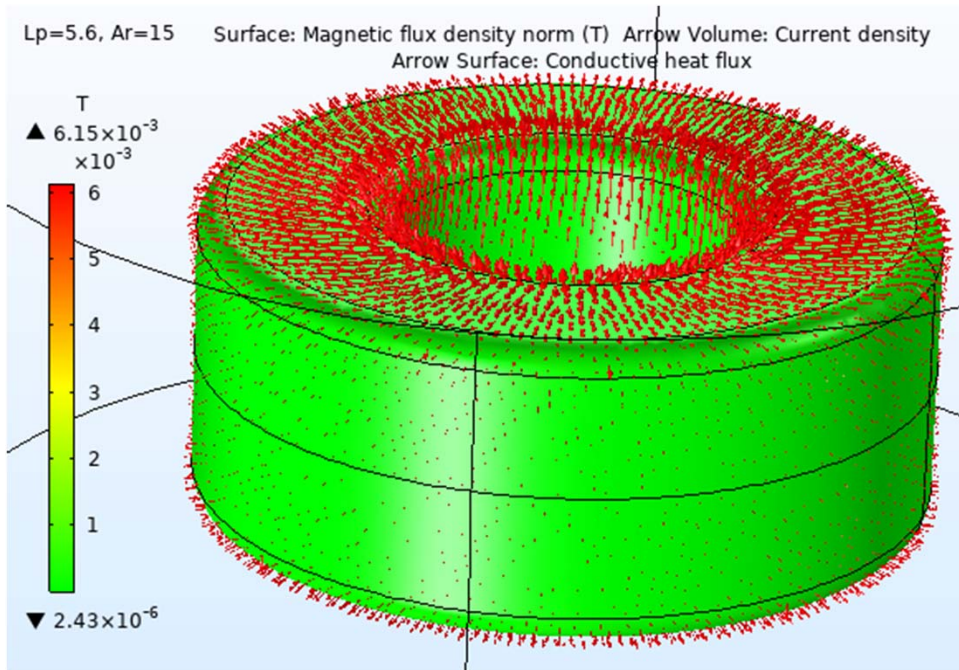

# Abbreviations

Ld	: Current rated Amps
Ar	: Airflow
W/m <sup>2</sup> .K	: Watts / Sq meter .Kelvin – Heat Convection rate
m/s	: Meter/ Second - Airflow
degC	: Temperature in Deg C
T	: Tesla – Magnetic Flux density
Temp	: Temperature
Temp max:	Temperature Maximum
Amb	: Ambient Temperature
Amps	: Ampere Load current.
Slice	: Sectional view

Disclaimer :

- Simulation MODEL is an effective tool for evaluating product performance by simulation; however, it does not simulate product performance in all test environments and is not intended to be a replacement for testing of the actual device by means of a test board or otherwise.
- Simulation results are for reference purposes only; CUSTOMER shall perform thorough testing using the actual device.