

# Thermal and Electromagnetics simulation – Part # HF467-130M-80AV – Current rated 80A @ 1kHz

Current 30% (24A)  
No Airflow  
Natural convection

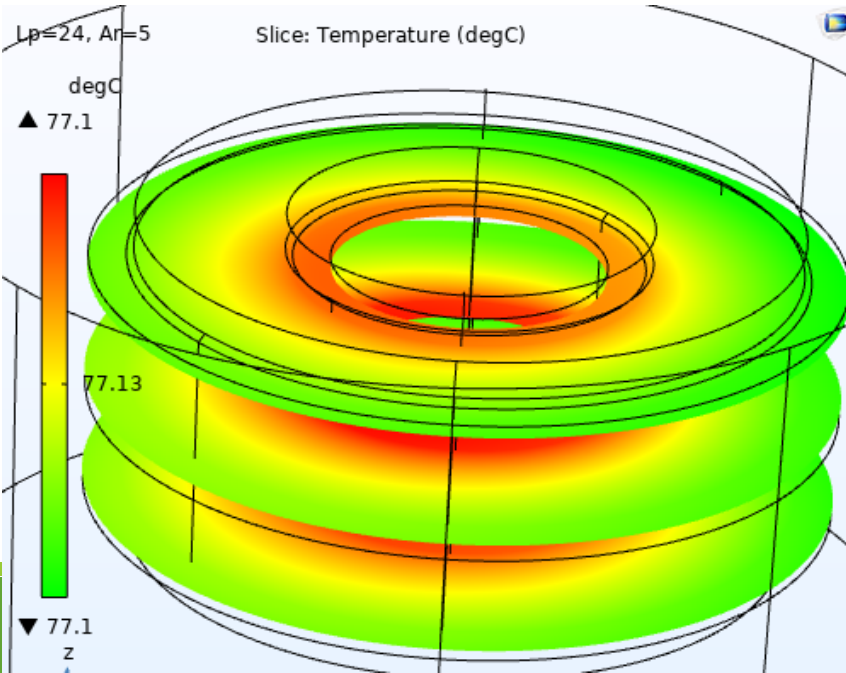

Current 70% (56A)  
15 W/ (m²K) or 3 m/s  
airflow.

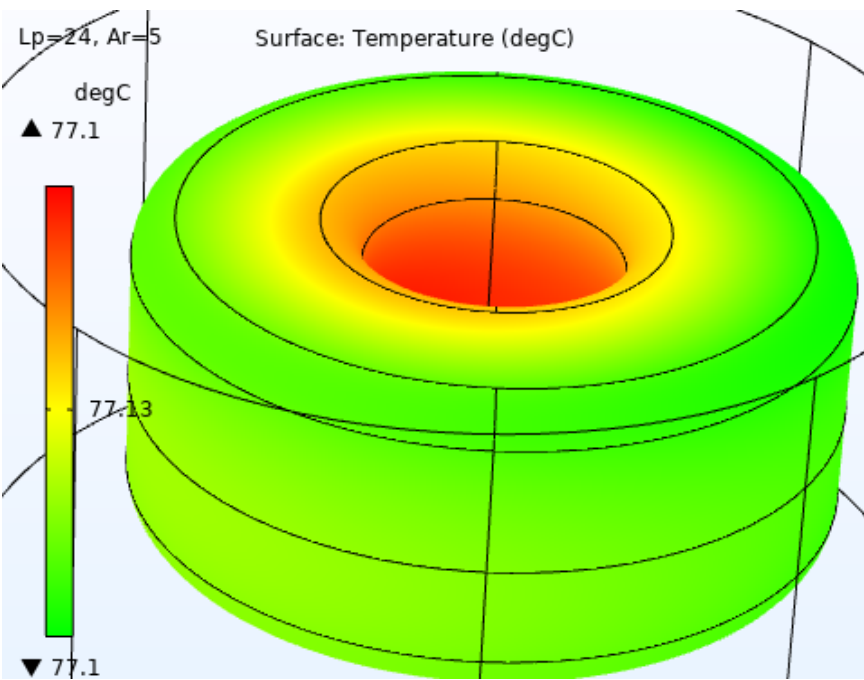
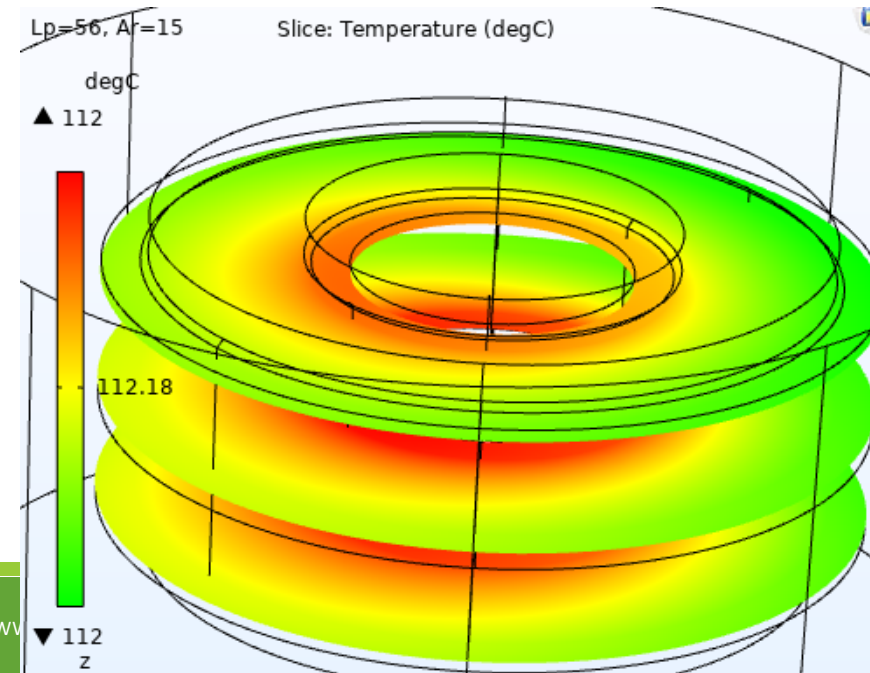
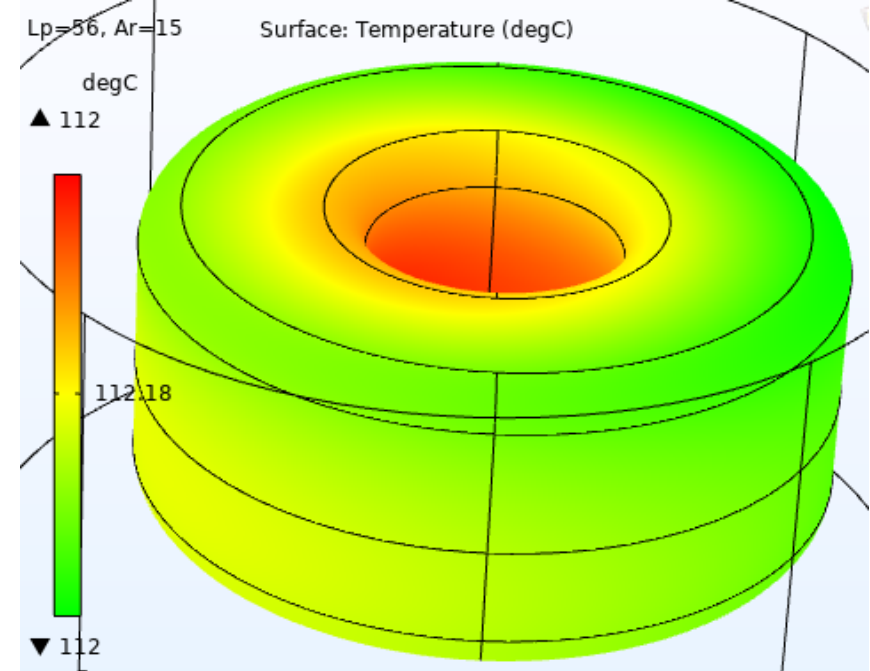

# Thermal and Electromagnetics simulation - Part # HF467-130M-80AV – Current rated 80A @ 1kHz

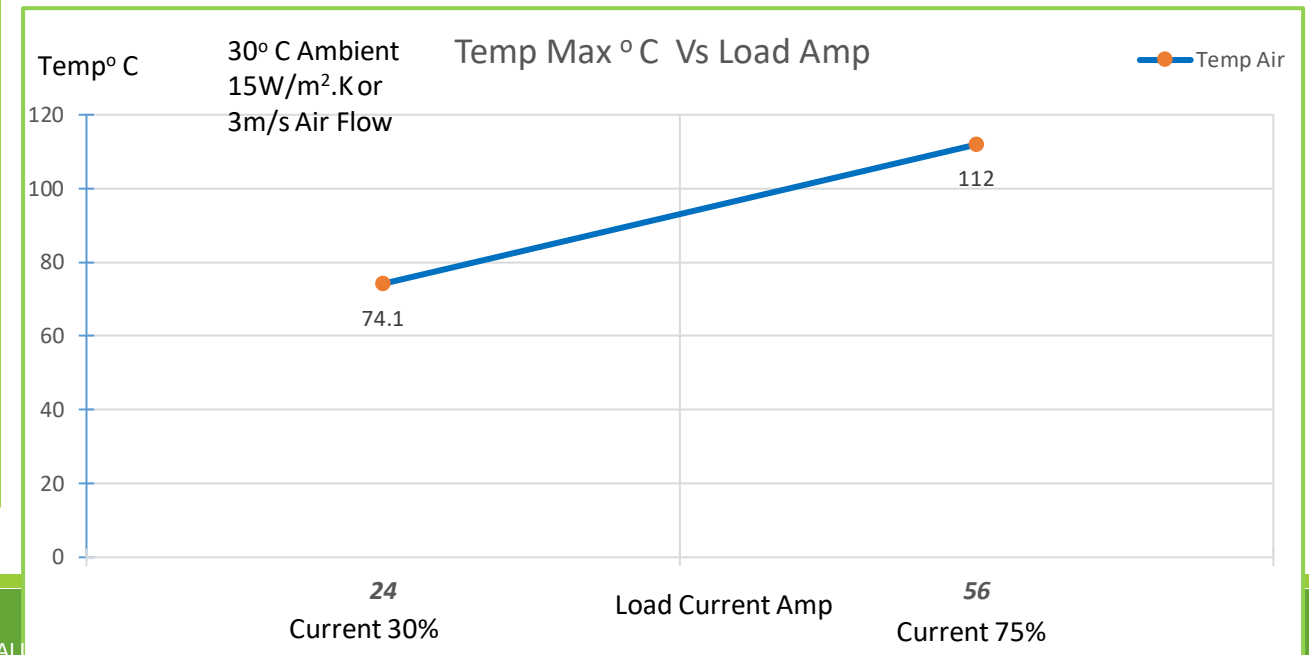
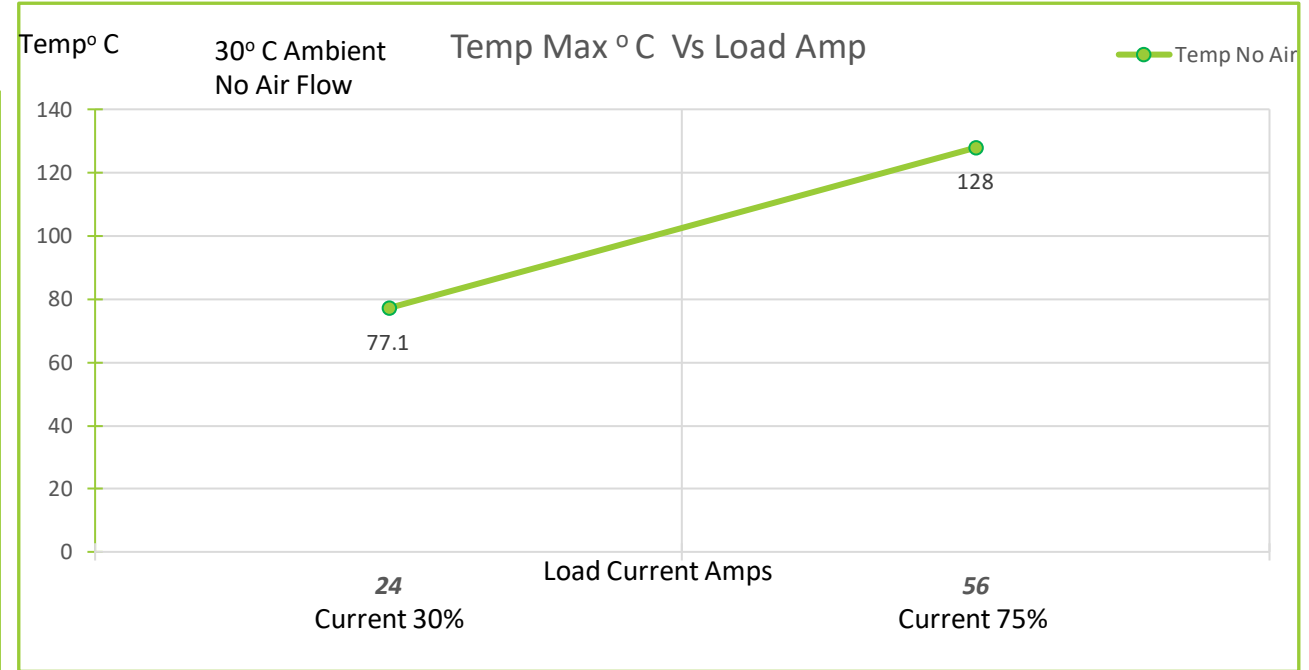
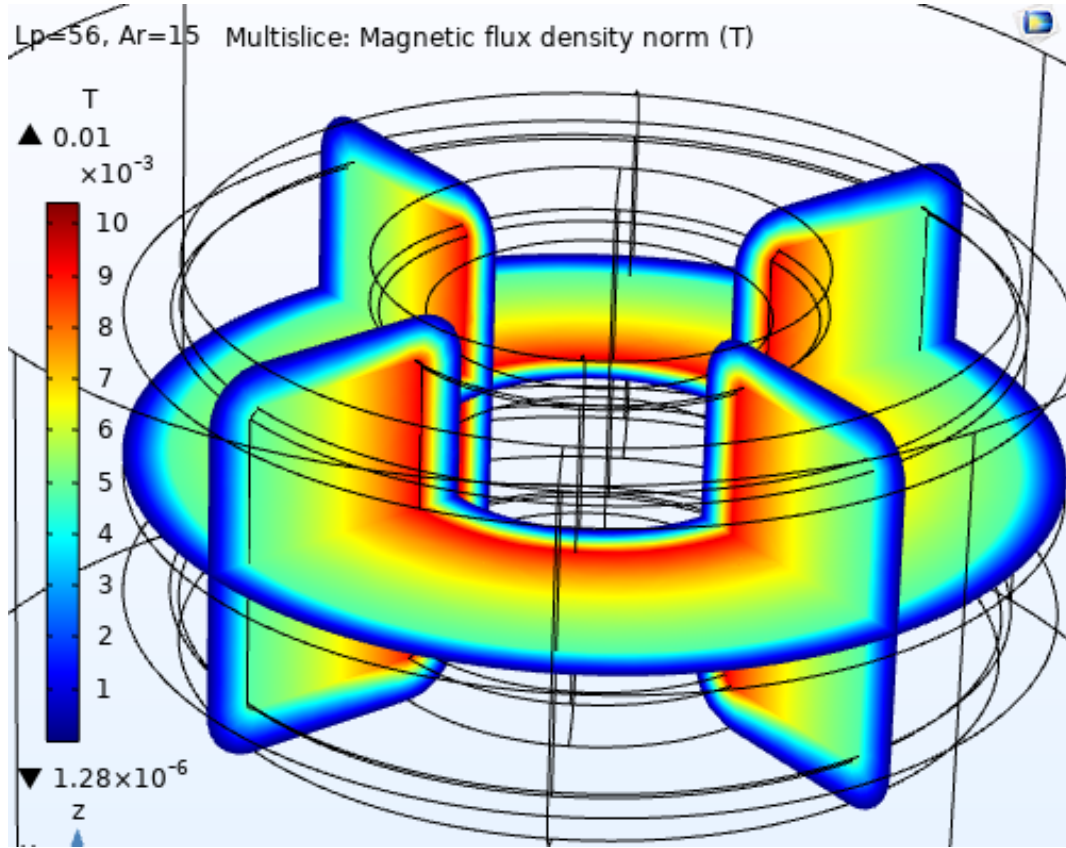

### Magnetics Flux in Coil

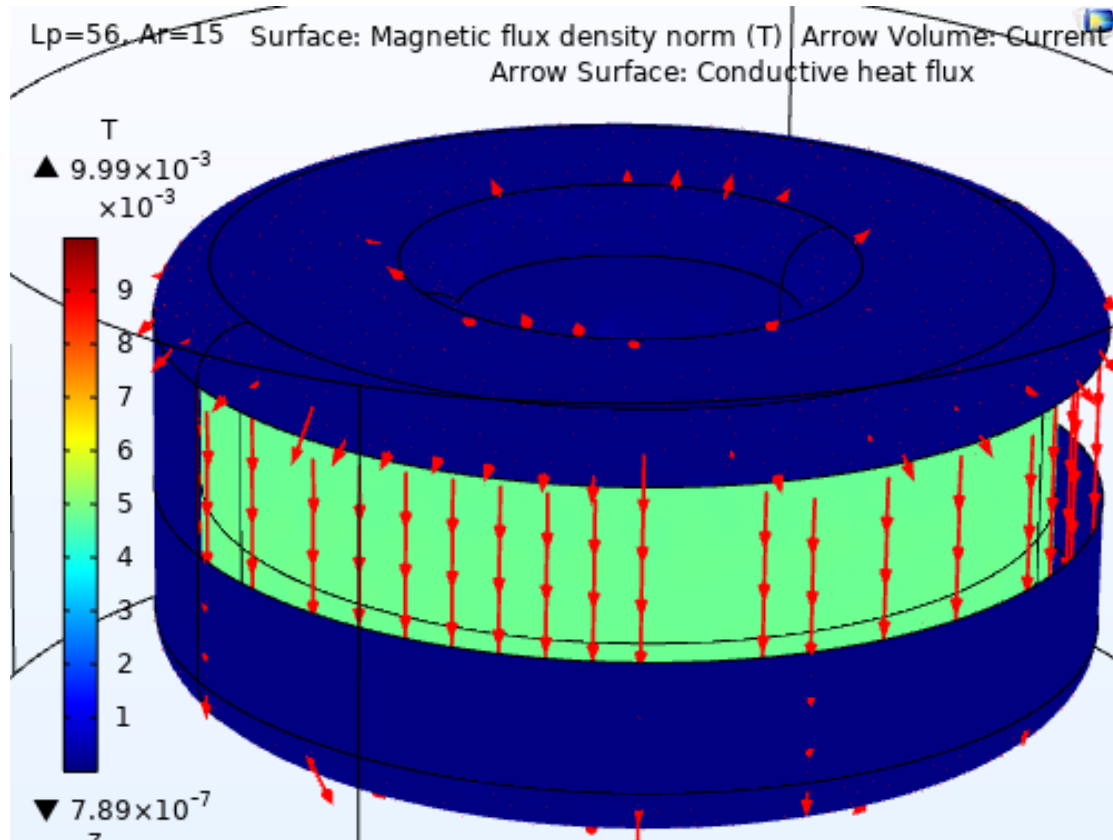

### Magnetic Flux in Core

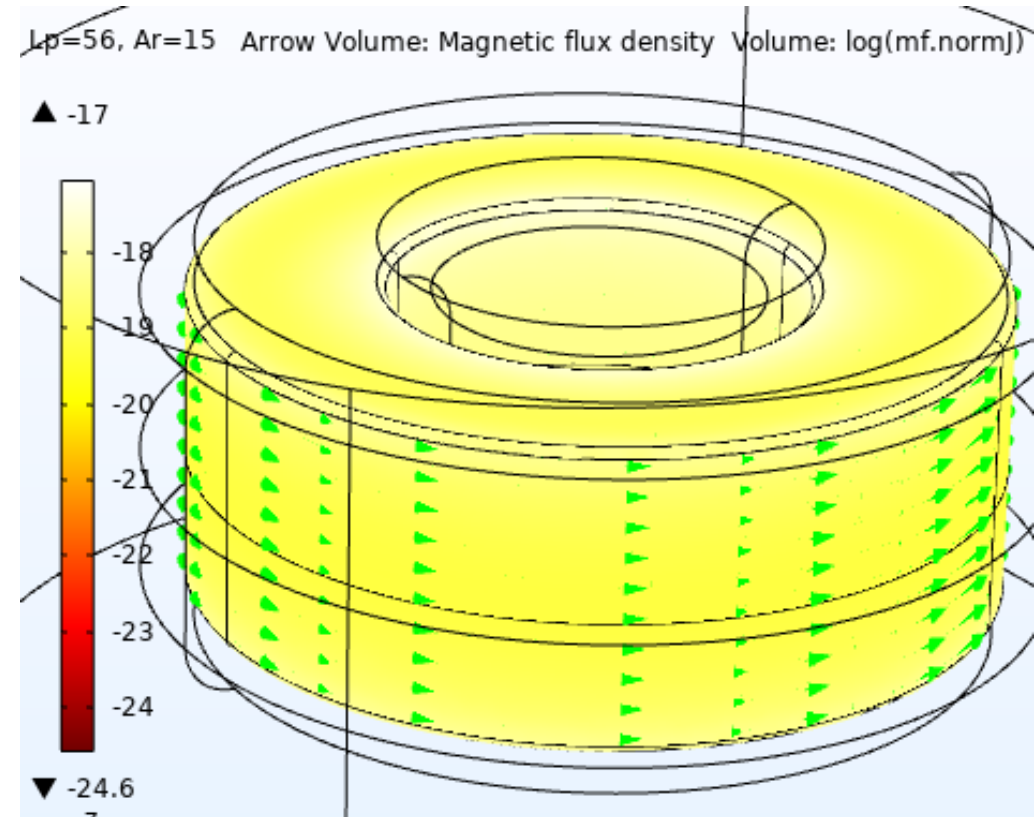

# Abbreviations

Ld	: Current rated Amps
Ar	: Airflow
W/m <sup>2</sup> .K	: Watts / Sq meter .Kelvin – Heat Convection rate
m/s	: Meter/ Second - Airflow
degC	: Temperature in Deg C
T	: Tesla – Magnetic Flux density
Temp	: Temperature
Temp max:	Temperature Maximum
Amb	: Ambient Temperature
Amps	: Ampere Load current.
Slice	: Sectional view

Note : For the modeling purpose the winding is considered as homogenous multilayer winding .

Disclaimer :

- Simulation MODEL is an effective tool for evaluating product performance by simulation; however, it does not simulate product performance in all test environments and is not intended to be a replacement for testing of the actual device by means of a test board or otherwise.
- Simulation results are for reference purposes only; CUSTOMER shall perform thorough testing using the actual device.