

The information contained in this drawing is the sole property of CWS Coil Winding Specialist. Any reproduction in part or whole without written permission of CWS Coil Winding Specialist is prohibited.

REVISION HISTORY			
REV	ECN	DESCRIPTION	DATE
A		PRODUCTION RELEASE	1/16/05

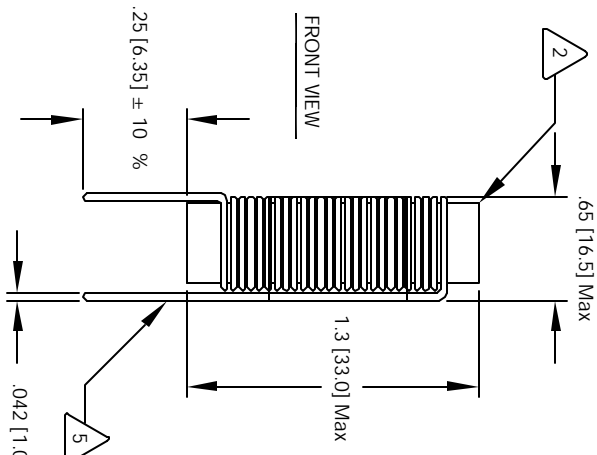

- INDUCTANCE DROPS 10% FROM ZERO ADC VALUE SATURATION CURRENT IS THE CURRENT AT WHICH THE TEMP. RISE ABOVE AMBIENT OF 25 °C.
- MAX DC CURRENT IS AVERAGE CURRENT FOR 40 °C NOTES:  
EPOXY LEADS TO CORE  
.05" ABOVE THE CORE EDGE, AND  
REMOVE INSULATION AND TIN LEADS
- WIND COILS EVENLY SPACED
- CONSTRUCTION:  
MAX TEMP RISE AT MAX CURRENT = 40 °C  
HI-POT TEST FOR CORE TO WINDING = 500 VDC  
DCR = 65 MILLI-OHMS MAX @ 25 °C  
SATURATION CURRENT = 5 AMPS  
L = 150 uH ± 10% , 15.75 KHz, 0.1 Vrms, 0 ADC.

**MOUNTING HOLES PATTERN**

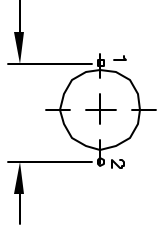

- WIRE: UL RECOGNIZED 130°C RATED MAGNET WIRE  
CWS BYTE-MARK OR OTHER APPROVED PART  
CORE: MANGANESE ZINC FERRITE ROD
- RATING CLASS B (130°C) REQUIRED  
MATERIAL: WIRE INSULATION - UL RECOGNIZED 94V-0 FOR FLAMMABILITY

NOTES: UNLESS OTHERWISE SPECIFIED, POWER INDUCTOR, DIMENSIONS IN INCHES [MM], READ FROM BOTTOM UP

CODE IDENT	MFG. P/N	DESCRIPTION	ITEM NO.
AUTOCAD SOLIDWORKS SIGN	X	<b>PARTS LIST</b>	
DATE	DATE	CWS Coil Winding Specialist 1510 E. Edinger Ave. Unit B, Santa Ana, CA 92705	
DRAWN TKK	1/16/05	<b>Power Chokes</b>	
CHKD JLAU	1/16/05	<b>Vertical Mount</b>	
ENGR KSUN	1/16/05	SIZE DIM. IN.	REV
APPR. JLAU	1/16/05	<b>B</b>	<b>A</b>
		SCALE <b>2=1</b>	SHEET <b>1</b> OF <b>1</b>