

The information contained in this drawing is the sole property of CWS Coil Winding Specialist. Any reproduction in part or whole without written permission of CWS Coil Winding Specialist is prohibited.

REVISION HISTORY			
REV	ECN	DESCRIPTION	DATE
A		PRODUCTION RELEASE	12/11/04

VERTICAL MOUNT
 .50 [12.7] Max

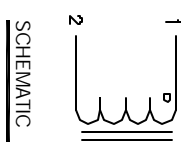
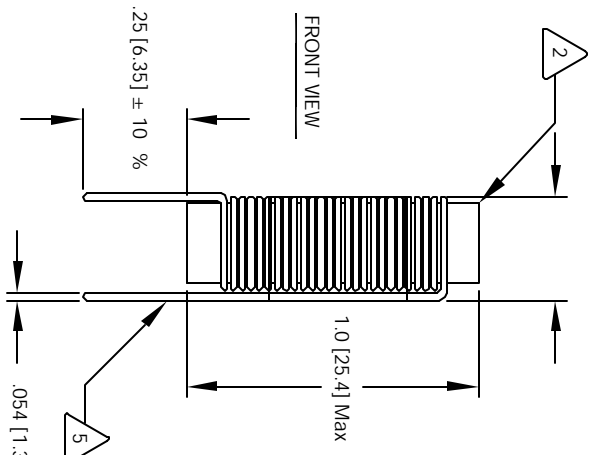

- 6 INDUCTANCE DROPS 10% FROM ZERO ADC VALUE SATURATION CURRENT IS THE CURRENT AT WHICH THE TEMP. RISE ABOVE AMBIENT OF 25 °C.
- MAX DC CURRENT IS AVERAGE CURRENT FOR 40 °C NOTES:
- LEADS MUST BE TANGENT TO THE CORE
- .05" ABOVE THE CORE EDGE, AND
- REMOVE INSULATION AND TIN LEADS

- 5 WIND COILS EVENLY SPACED
- 4 CONSTRUCTION:
- MAX TEMP RISE AT MAX CURRENT = 40 °C
- HI-POT TEST FOR CORE TO WINDING = 500 VDC
- DCR = 5 MILLI-OHMS MAX @ 25 °C
- SATURATION CURRENT = 10 AMPS
- L = 3.3 uH ± 15% . 15.75 KHZ, 0.1 Vrms, 0 ADC;
- 3 SPECIFICATIONS: MAX RMS (DC) CURRENT = 10 AMPS

- 2 WIRE: UL RECOGNIZED 130°C RATED MAGNET WIRE
- CWS BYTE-MARK OR OTHER APPROVED PART
- CORE: MANGANESE ZINC FERRITE ROD

- 1 RATING CLASS B (130°C) REQUIRED
 - MATERIAL: WIRE INSULATION - UL RECOGNIZED 94V-0 FOR FLAMMABILITY
- NOTES: UNLESS OTHERWISE SPECIFIED, POWER INDUCTOR, DIMENSIONS IN INCHES [MM], READ FROM BOTTOM UP

MOUNTING HOLES PATTERN

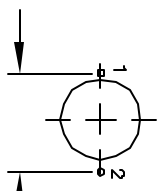

CODE IDENT	MFG. P/N	DESCRIPTION	ITEM NO.
AUTOCAD SOLIDWORKS SIGN	X	PARTS LIST	
UNLESS OTHERWISE SPECIFIED TOLERANCE PER NAS 11.5M ALL DIMENSIONS ARE IN NOTES AND [DIMENSIONS]	DATE	CWS Coil Winding Specialist www.cwswind.com	
TOLERANCE INCHES HOLE ±.002 .X±.015 TOLERANCE METERS HOLE ±.127 .X±.38	DATE	1510 E. Edinger Ave Unit B, Santa Ana, CA 92705	
ANGLE PROJECTION	DATE	Power Chokes Vertical Mount	
DO NOT SCALE DRAWING	DATE	SIZE DIM. IN. B	REV A
	DATE	SCALE 2=1	SHEET 1 OF 1