

The information contained in this drawing is the sole property of CWS Coil Winding Specialists. Any reproduction in part or whole without written permission of CWS Coil Winding Specialists is prohibited.

REVISION HISTORY

REV	ECN	DESCRIPTION	BY	DATE	CHK	DATE
B		PRODUCTION RELEASE	RPB	5/31/06	JLJU	5/31/06

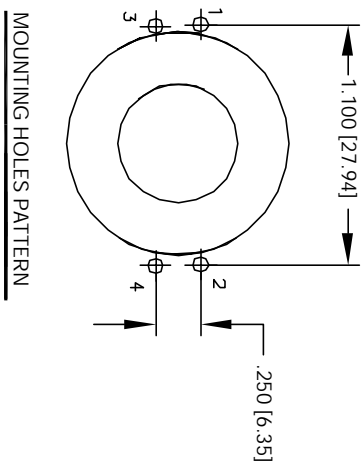
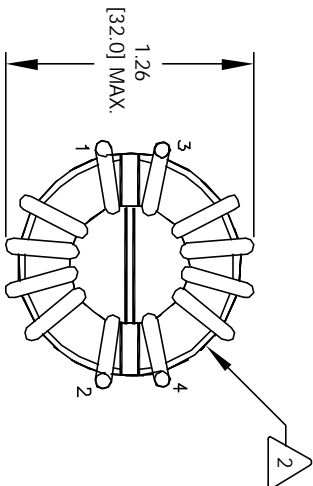
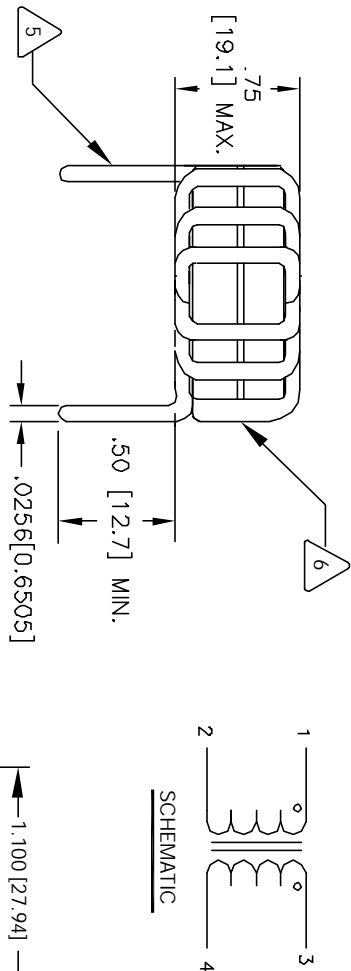

- 7 BUILT TO ROHS COMPLIANCE AND LEAD FREE.
WHERE SHOWN
IF APPLICABLE MARK PART NUMBER
- 6 FLUSH WITH THE COIL EDGE, AS SHOWN
- 5 REMOVE INSULATION AND TIN LEADS APPROX. 0.5 INCH
WIND ON EACH SIDE TO CORE AND EVENLY SPACED
- 4 CONSTRUCTION:
TEMP RANGE = -25 °C TO 120°C
MAX TEMP RISE = 40 °C
TEST VOLTAGE = 2000 VAC, 1 MIN.
TOTAL DCR OF BOTH WINDINGS = 52.9 MILLIOHMS COMBINED.
RATED VOLTAGE = 250 VAC OR VDC
RATED CURRENT = 5 AMPS
L = 1.0 mH MIN., 50 Hz - 400 KHz, 0.250 Vrms, 0 ADC
INSULATION RESISTANCE = 100 MEGA-OHMS MIN. @ 500 VDC
SPECIFICATIONS AT 25°C:
APPROVED PART
WIRE: UL RECOGNIZED 200°C RATED MAGNET WIRE
CWS BYEMARK OR OTHER APPROVED PART
CORE: FERRITE TOROID, HIGH PERMMNZN
- 2 BOBBIN RATING CLASS B (200°) REQUIRED
1 MATERIAL: UL RECOGNIZED 94V-0 FOR FLAMMABILITY

NOTES: UNLESS OTHERWISE SPECIFIED,
READ FROM BOTTOM UP.

EP FORM0005 REV 3 10/01

UNLESS OTHERWISE SPECIFIED	DO NOT SCALE DRAWING
DIMENSIONING AND TOLERANCE PER ANSI Y14.5M	
ALL DIMENSIONS ARE IN INCHES AND (DIMENSIONS)	
TOLERANCE INCHES: .XXX = ±.005 .XX = ±.015 .X = ±.030	
TOLERANCE METRCS: .XXX = ±.127 .XX = ±.254 .X = ±.508	
ANGLE PROJECTION	

QTY	CODE	MFG. P/N	DESCRIPTION	ITEM NO.
	IDENT			
	X			
PARTS LIST				
AUTOCAD SOLIDWORKS SIGN		CWS Coil Winding Specialist. 353 W. GROVE AVENUE ORANGE, CA. 92665		
DATE	DATE	TITLE		
5/31/06	5/31/06	Common Mode Chokes Horizontal Mount		
ENGR. JLJU	ENGR. KSUM			
APPR. JLJU	APPR. JLJU	SIZE	SCALE	REV
5/31/06	5/31/06	B	2=1	B
		HL-H-102U-5A		
		SHEET 1	OF 1	1

CAD-FILE: