

The information contained in this drawing is the sole property of CWS Coil Winding Specialist. Any reproduction in part or whole without written permission of CWS Coil Winding Specialist is prohibited.

REVISION HISTORY

REV	ECN	DESCRIPTION	DATE	BY	CHK	DATE
0		PRODUCTION RELEASE	9/08/04	JLU		9/08/04

FRONT VIEW

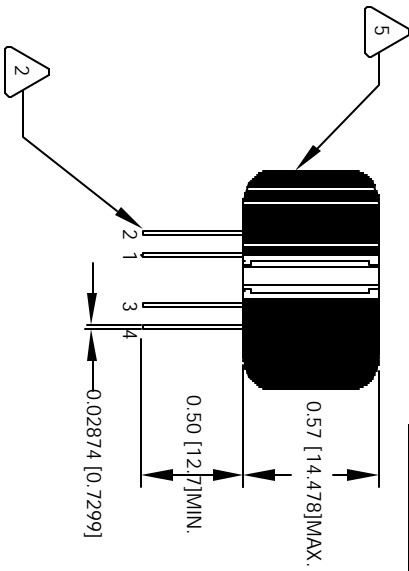

6 IF APPLICABLE, MARK PART NUMBER AND REVISION

5 FLUSH WITH THE COIL EDGE, AS SHOWN
REMOVE INSULATION AND TIN LEADS

4 WIND ON EACH SIDE OF CORE AND EVENLY SPACED
CONSTRUCTION:

TEST FREQUENCY = 10 KHZ
TEMP RANGE = -25 °C TO 120 °C
MAX TEMP RISE = 30.8 °C
TEST VOLTAGE = 2000 VAC, 1 MIN
RATED VOLTAGE = 250 VAC OR VDC
RATED CURRENT = 3.0 AMPS
TOTAL DCR OF BOTH WINDINGS = 0.0659 OHMS MAX COMBINED
L = 1.0 mH NOMINAL, 50 Hz - 400 KHz, 0.250 Vrms, 0 ADC
INSULATION RESISTANCE = 100 MEGA-OHMS MIN. @ 500 VDC
SPECIFICATIONS AT 25 °C

3 WIRE: UL RECOGNIZED 130°C RATED MAGNET WIRE
CWS BYTE-MARK OR OTHER APPROVED PART
CORE: FERRITE TOROID.

2 BOBBIN RATING CLASS B (130°C) REQUIRED
MATERIAL: UL RECOGNIZED 94V-0 FOR FLAMMABILITY

NOTES: UNLESS OTHERWISE SPECIFIED, COMMON MODE CHOKE

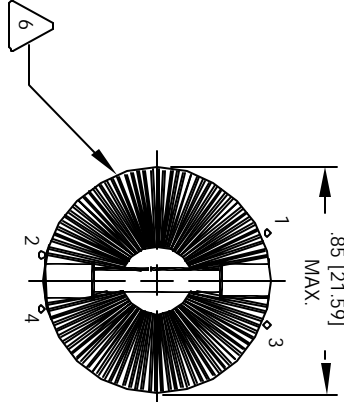

BOTTOM VIEW

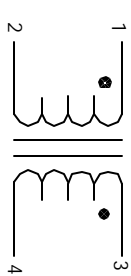

SCHEMATIC

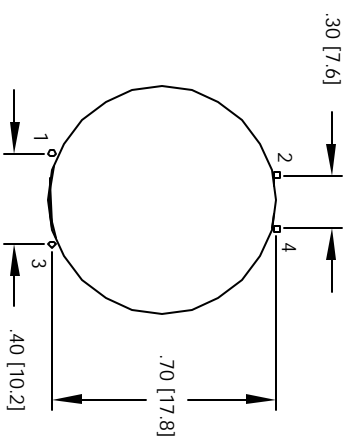

MOUNTING HOLES PATTERN

UNLESS OTHERWISE SPECIFIED	
DRAWING AND TOLERANCE PER ANSI Y14.5M	
ALL DIMENSIONS ARE IN INCHES AND [MILLIMETERS]	
TOLERANCE INCHES: .XXXX = .015	±.030
TOLERANCE METERS: .XXXX = .254	±.075
ANGLE PROJECTION	AS SHOWN
DO NOT SCALE DRAWING	

QTY	CODE	MFG. P/N	DESCRIPTION	ITEM NO.
	IDENT			
	X			
AUTOCAD SOLIDWORKS SIGN		PARTS LIST		
DATE	DATE	CWS Coil Winding Specialist 1510 E. Edinger Ave. Unit B, Santa Ana, CA 92705		
9/09/04	9/09/04	Common Mode Chokes		
9/09/04	9/09/04	SIZE	REV	
9/09/04	9/09/04	DWG. NO.	D	
9/09/04	9/09/04	LFH-102U-3A		
9/09/04	9/09/04	SCALE	SHEET	1 OF 1
9/09/04	9/09/04	2=1		